

LED-Framed Touch Monitor

USER MANUAL

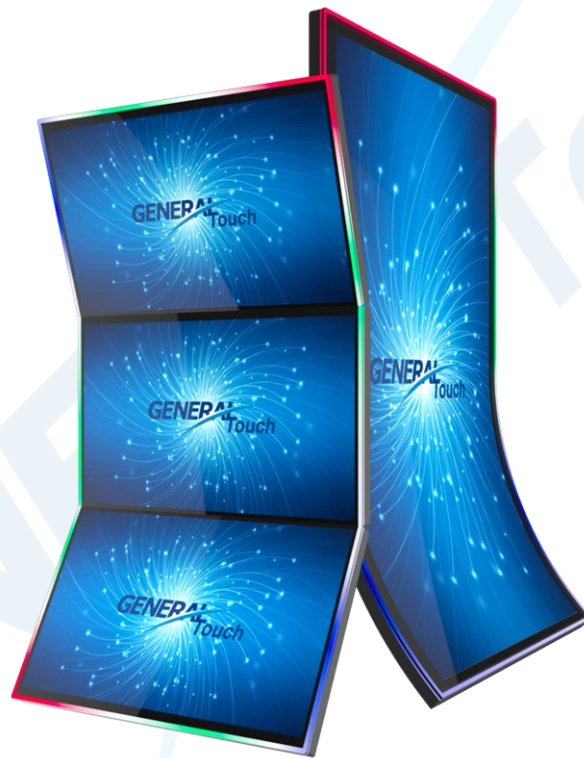

Please read this manual carefully and keep it
in a safe place before use.

V1.3 2026.06



This manual is copyrighted and owned by General Touch Co., Ltd. (referred to as "General Touch"). Without written authorization from General Touch, any individual or entity is prohibited from copying, scanning, storing, disseminating, reprinting, selling, transferring, or modifying the entire or partial content of this manual in any way, whether for personal or third-party use. This manual and its content are solely intended for the operation and use of the LED-framed touch display series products and should not be used for any other purposes.

The images in this manual (including but not limited to their models, appearance, colors, dimensions, screen display content, etc.) are for illustrative purposes only. Please refer to the actual product for accuracy.

READING TIPS

Symbol Key

	Note or Information		Warning		Caution
---	---------------------	---	---------	---	---------

USAGE RECOMMENDATIONS

General Touch provides you with the following documentation:

"Sales Drawing"

"Specification Sheet"

"User Manual"

We recommend starting with the "Specification Sheet" to learn about the LED-Framed touch monitor's specifications and structural dimensions. For more information, refer to the "Sales Drawing". To fully understand the product, please read the "User Manual."

The introductory page of each chapter in the user manual provides an overview of the chapter's content.

This manual is intended for LED-Framed touch monitor.

CATALOGUE

Reading tips	2		
1 Precautions Before Use.....	2		
1.1 Safety Precautions.....	2		
1.1.1 Safety Precautions for Using a DC Power Supply	3		
1.2 Delivery Status.....	4		
1.3 Delivery Checklist	4		
1.4 Preparation	5		
1.5 FCC Statement	6		
2 Overview	8		
2.1 Define	8		
2.2 Main Features	8		
2.3 Application scenarios	8		
3 production description	10		
3.1 Exterior	10		
3.2 Structure	12		
3.3 I/O Connectors.....	14		
3.3.1 Touch Monitor Interface.....	14		
3.3.2 LED Strip Connector Interfaces and Definitions	16		
3.4 LED Strip Description.....	19		
3.4.1 RGB LED strip	19		
3.4.2 Addressable RGB LED strip	19		
3.4.3 Break-point Continuous Transmission	19		
3.5 Touch Functions	20		
4 Mounting and Operation instructions	22		
4.1 Mounting Design.....	22		
4.2 Usage	22		
4.2.1 A Touch Monitor	22		
4.2.2 Combo Touch Monitor	23		
4.3 Packing and Unpacking	25		
4.4 Mounting type	25		
4.4.1 Flat Touch Monitor	26		
4.4.2 Curved Touch Monitor	27		
5 Instructions for Use	29		
5.1 LED Controller	29		
5.1.1 I/O Connector and define... ..	29		
5.1.2 How to use LED Controller	30		
5.1.3 LEDBarTool Instructions....	30		
5.1.4 Extension.....	31		
5.2 The LED Controller and LED Strip Connection.....	31		
5.2.1 Single Touch Monitor.....	32		
5.2.2 Combo Touch Monitor	33		
5.2.3 Powering the LED strips	34		
5.2.4 Others.....	34		

6 OSD menus Setup.....	36	9 Appendix.....	67
6.1 OSD buttons description	36	9.1 Specifications.....	67
6.2 OSD Menu Overview	38	9.1.1 Dimensions	67
6.2.1 User Interface 1	38	9.1.2 Technical Indicators.....	67
6.2.2 User Interface 2	40	9.1.3 Environmental Adaptability	67
6.2.3 User Interface 3	42	9.2 Terms.....	67
6.2.4 User Interface 4	45	9.3 Contact Us	67
7 Troubleshooting Guide	56		
7.1 Types of Malfunctions	56		
7.2 Troubleshooting Process	56		
7.3 Common Malfunction Reference Table.....	56		
8 Service and Support	63		
8.1 Pre-sales Consultation.....	63		
8.2 After-sales Service.....	63		
8.2.1 After-sales Process.....	63		
8.2.2 Warranty Policy.....	64		
8.2.3 Service Assurance.....	64		
8.3 Customization Services	64		
8.4 Debugging and Firmware Upgrades	65		
8.4.1 Debugging	65		
8.4.2 Firmware Upgrades	65		

PRECAUTIONS BEFORE USE

This section primarily covers some important points to note when using the product.

GENERATOR TOUCH

1 PRECAUTIONS BEFORE USE

1.1 Safety Precautions



Here are some safety precautions to be followed when using our product. Please read and adhere to them carefully.

Before cleaning the product, make sure to unplug the power cord, and wipe the product with a soft, dry cloth.

Do not use components other than those recommended by the manufacturer, as it may cause damage.

Do not attempt to drag the monitor by its power cord, and do not touch the plug with wet hands.

Avoid excessive bending of the plug and power cord, and do not place heavy objects on them to prevent damage.

Place the product in an area away from oil, smoke, or moisture to avoid malfunction, electric shock, or fire. Particularly, avoid operating the monitor near water or outdoors where it may be exposed to rain or snow.

Do not block the ventilation openings on the monitor casing, and do not place the monitor or power adaptor on a bed, sofa, carpet, etc., as poor ventilation may cause malfunctions or fire.

When installing the product, ensure that it is positioned at least 76 mm away from the wall for proper ventilation.

Use only the power source type listed on the product label. If you have any doubts about the power source, please contact local dealer or power supply department.

Use only properly grounded plugs and outlets, as improper grounding may result in electric shock or device damage. If plug cannot be inserted into the outlet, please replace the outlet.

Ensure that the outlet can handle the total electrical load of the connected product. Do not connect too many extension cords or plugs to a single outlet, as it may cause a fire.

Do not place the product on an unstable or narrow surface. Place it on a flat and stable surface to prevent the product from falling and causing harm to passersby, especially children.

Do not attempt to extend the power cord, as it may cause a fire.

Do not disassemble the monitor case by yourself. If the monitor needs inspection or repair, please contact a professional service technician.

In case of the following situations, unplug the power cord first and then contact a professional service technician:

- ◆ The power cord is damaged or broken.
- ◆ The monitor fell and damaged the casing.
- ◆ The monitor display is not functioning correctly and needs to be repaired.

When not using the monitor, unplug the power cord from the power outlet.

Do not install the product in areas with poor ventilation, strong direct light, high temperature, or high humidity.

It is important to note that the corners of the tempered glass are relatively fragile. Therefore, it is essential to exercise caution and protect the four corners of the touch screen throughout the entire process of installation and use. This is to prevent any potential damage from contact with sharp objects or from impact.

1.1.1 Safety Precautions for Using a DC Power Supply

To ensure safe equipment operation, please comply with the following regulations when using a DC power supply.



Mandatory Protection Measures:

The DC power supply used must be equipped with an overcurrent protection circuit (OCP). It is strictly forbidden to connect any bare power supply without overcurrent protection functionality (such as simple batteries, transformers, or switching power supplies that are unregulated or lack a protection circuit).

For the best user experience and device stability, we recommend using our original factory adapter. If you need to use a third-party DC power supply, please refer to the parameters in the table below for selection and ensure that the power supply is equipped with overcurrent protection (OCP). Choosing the right power supply contributes to long-term stable operation of the device.

Rated Voltage	Typical Power Consumption	Rated Current	Recommended Supply-side Threshold Current
12V	50W	4.17A	5.0A
	60W	5.0A	5.8A
	90W	7.5A	9.0A
24V	150W	6.25A	7.5A

Note: For DC power supply specifications applicable to different monitor models, please refer to the detailed adapter descriptions in the "Optional Accessories" section of the specification sheet.

1.2 Delivery Status

According to the product specifications, all components are delivered with specific hardware or software configurations, including firmware versions. It is important to note that any modifications or changes made to the hardware or software configurations (including firmware versions) beyond the specified limits are not allowed for this product. In such cases, General Touch (the company) will not be held responsible for any consequences or liabilities that may arise.

1.3 Delivery Checklist

Number	Name	Quantity	Remarks
1	Touch monitor	1	
2	Power cable	1	
3	Power adaptor	1	
4	USB cable (Type-B to Type-A)	1	For Touch Monitor
5	Video Cable	1	VGA, HDMI, etc.
6	LED controller kits ¹	1	For LED strip control, including cables
7	Specification sheet	1	Electronic version
8	Sales drawing ²	1	Electronic version
9	User manual	1	Electronic version

Note: Due to variations in specific models within this product series, please refer to the actual provided model for accuracy.

¹ The customer is responsible for providing their own LED controller if they choose to do so. This item is not included in the delivery list.

² The sales drawings consist of a floor plan in PDF format and a three-dimensional model in STP format.

1.4 Preparation

This manual is designed for LED-Framed touch monitors and covers basic information such as product introduction, installation and usage instructions, troubleshooting, and more.

For our touch monitor, it is important that the operators have a certain level of professional knowledge and experience.

Here are some essential elements to ensure the proper functioning of the touch monitor:



The power supply that matches the specifications of the touch monitor.

Before preparing to use the touch monitor, please make sure to determine the power supply that matches its specifications.

When installing and disassembling, it is necessary to turn off the power and then power on the monitor after assembly or installation is complete.



The touch monitor is compatible with certain operating systems for the host computer and supports specific video sources. It is important to use a compatible operating system for the host computer when using the touch monitor to ensure the touch functionality works properly. Using an incompatible operating system may result in the touch function not working or performing poorly.

Additionally, it is recommended to use a video source that has a resolution that is consistent with or supported by the touch monitor. Using a video source with an incompatible resolution may result in the inability to display content or poor display quality.



It is imperative that LED-Framed touch monitors be furnished with a LED controller and power supply that align with the prescribed specifications to forestall any potential damage to the LED strip.

1.5 FCC Statement

Caution:

Changes or modifications not expressly approved by the party responsible for compliance could void the user's authority to operate the equipment.

Note: This equipment has been tested and found to comply with the limits for a Class B digital device, pursuant to part 15 of the FCC Rules. These limits are designed to provide reasonable protection against harmful interference in a residential installation. This equipment generates, uses and can radiate radio frequency energy and, if not installed and used in accordance with the instructions, may cause harmful interference to radio communications. However, there is no guarantee that interference will not occur in a particular installation. If this equipment does cause harmful interference to radio or television reception, which can be determined by turning the equipment off and on, the user is encouraged to try to correct the interference by one or more of the following measures:

- ◆ Reorient or relocate the receiving antenna.
- ◆ Increase the separation between the equipment and receiver.
- ◆ Connect the equipment into an outlet on a circuit different from that to which the receiver is connected.
- ◆ Consult the dealer or an experienced radio/TV technician for help.

OVERVIEW

This section primarily focuses on introducing the features and applicable scenarios of this product series.

2 OVERVIEW

2.1 Define

A LED-framed touch monitor differs from an ordinary touch monitor in that it incorporates an LED strip, which serves not only to illuminate the edge of the touch monitor but also to illuminate the surrounding cabinet. Additionally, it is capable of changing color combinations in various modes at any given time, thereby creating an immersive atmosphere and enhancing the visual appeal of the product. P-cap touch cover glass can be integrated with attractive LED strip that offers more splendor to the design and more aesthetic-pleasance to the players.

2.2 Main Features

General Touch offers both the Open Frame and Closed Frame curved displays. For a flushing appearance when integrated into a cabinet, the Open Frame is the straightforward choice. The Closed Frame allows the display to float on the surface of the cabinet though VESA and hinge mounting options, adding a touch of sophistication. When combined with Halo/Edge/Front LED-Framed lights, the curved display looks like it is dancing rhythmically. If a Closed Frame is in floating mount, adding rear LED strips would produce a silhouette effect.

Curved display is a state-of-the-art and innovative solution for gaming applications where, it offers aesthetically-pleasant and much more immersive and vivid gaming experience than the flat screens.

The large-sized 43~55inch portrait curved touch screen provides an immersive and expansive user experience from top to bottom in diverse gaming and interactive scenarios. The medium-sized 23.6~32inch landscape curved touch screen design is based on user-centered ergonomics, reducing fatigue in the human-computer interaction process, allowing users to play longer, fuller and happier.

2.3 Application scenarios

LED-Framed touch monitors have been widely used in various scenes and domains, including gaming, kiosks, entertainment, EV chargers, meetings, and way-finding.

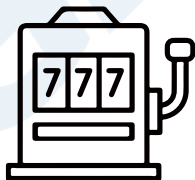

Gaming



Kiosk

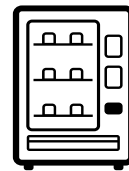

Vending Machine

PRODUCT DESCRIPTION

This chapter primarily covers the components, installations, usage, and routine maintenance of the product.

GENERATOR TOUCH

3 PRODUCTION DESCRIPTION

3.1 Exterior

General Touch offers a range of LED-framed touch monitor, available in various series and sizes.

The LED-Framed touch monitor dazzles with ambient lighting effects on the front and/or back of its sides. The color, style, and rhythm of the lights can be used as adornments, alerts, attractions, flags, indicators or fanfare that will surely boost the interactive functions of a touch display for both the users and operators.

Flat Touch Monitor (4 Sided Lighting)



Flat Touch Monitor (3 Sided Lighting)

Flat Touch Monitor (2 Sided Lighting)



Circular Touch Monitor

C type curved Touch Monitor

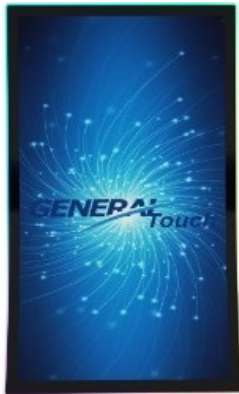
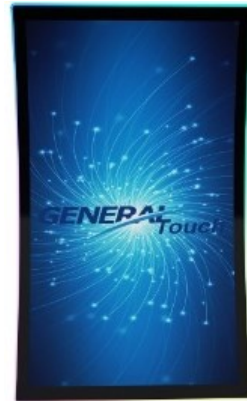

J type curved Touch Monitor



S type curved Touch Monitor



Double-Sided Displays

3.2 Structure

In comparison to a conventional touch panel, a light bar touch panel incorporates an LED strip within the touch panel, thereby producing a brilliant light through the light guide frame at the edge. The light guide frame is typically integrated with the front frame or touch screen, and the material used for the light guide frame is generally PC plastic or PMMA acrylic.

The selection of light strips for flat touch monitor is more flexible and varied. There are two main types of light strips: rigid LED strips and flexible LED strips.

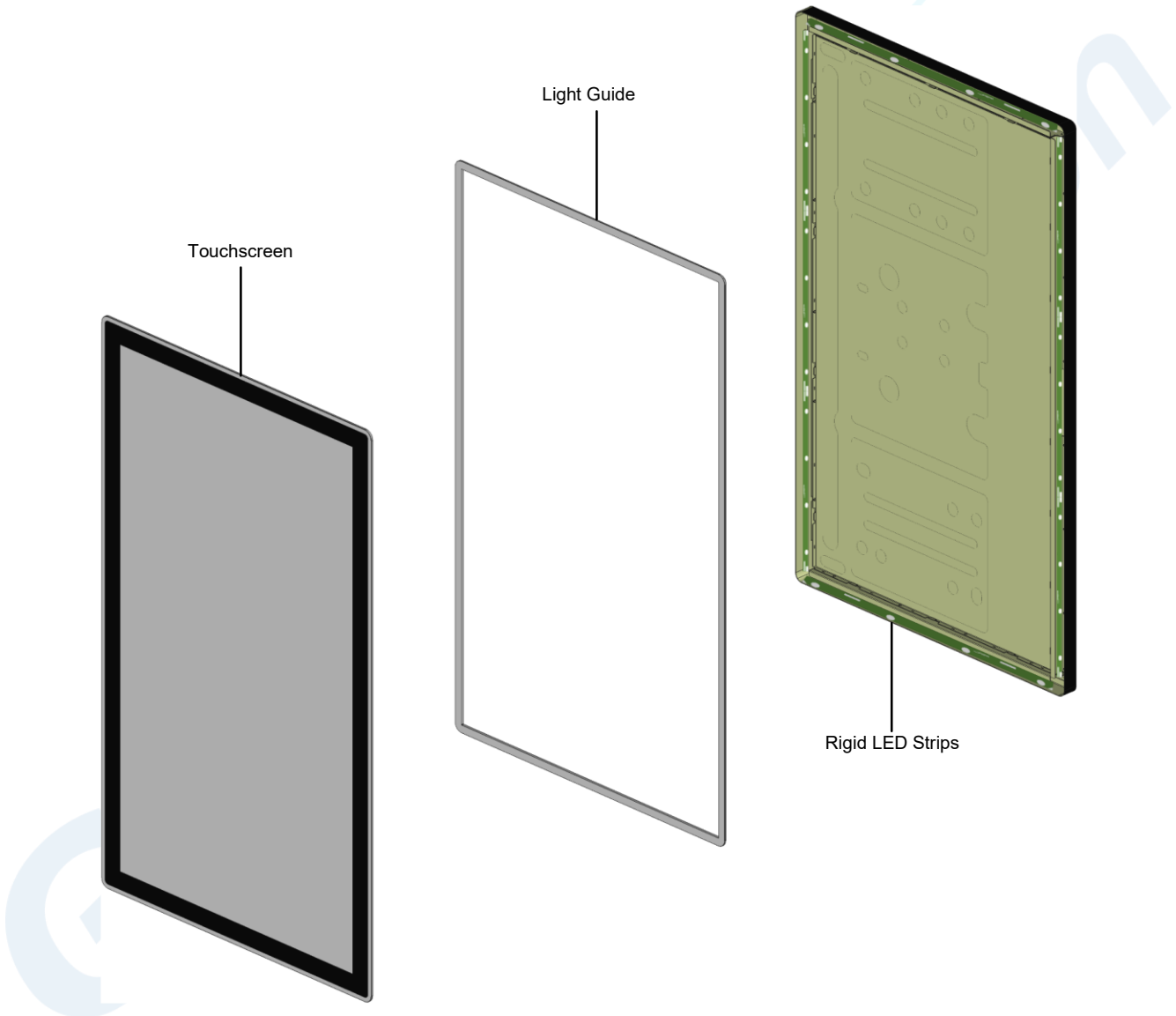

Fig 1 Cross-sectional view of the main structural components of a flat LED-framed Touch Monitor

In the case of curved touch monitor, the optimal choice is a flexible LED strip.

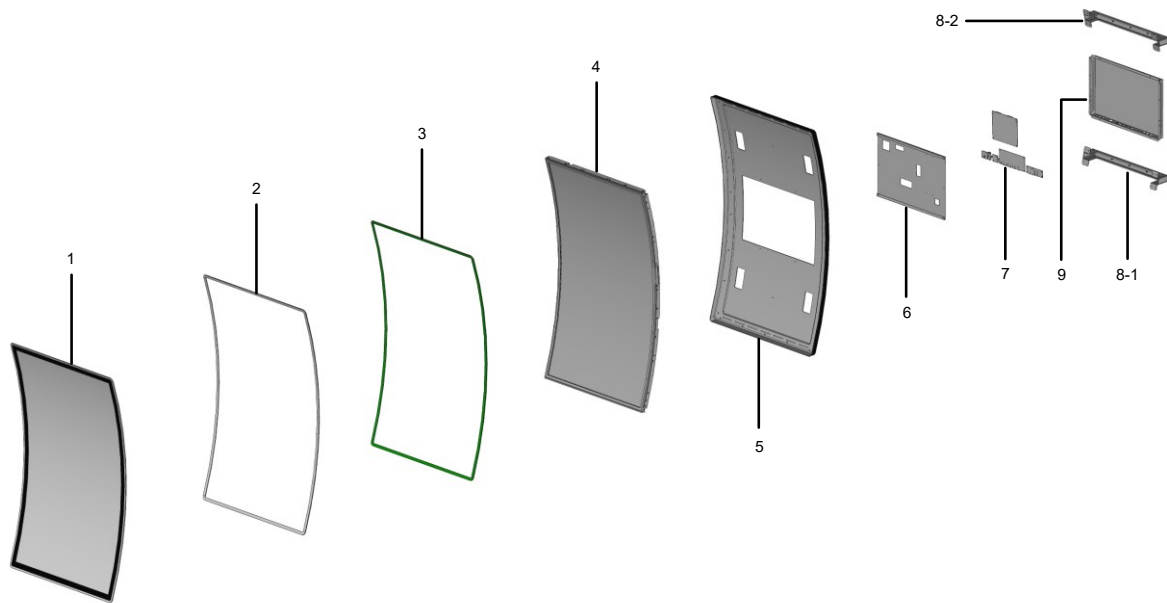

Fig 2 Cross-sectional view of the main structural components of a curved LED-framed touch monitor

LED-Framed Touch Monitor Component

<p>1 Touch Screen (include cover glass)</p> <p>Used for touch interaction</p>	<p>6 Metal Plate</p> <p>Provides fixation, fastening, and space for electronic components.</p>
<p>2 Light Guide</p> <p>It used to direct light from an LED to a place where the light is needed.</p>	<p>7 Electronic Components</p> <p>Includes A/D Board, LED strip connector Board</p>
<p>3 LED Strips</p> <p>Lighting</p>	<p>8 VESA Brackets</p> <p>For installing cabinets.</p>
<p>4 Panel</p> <p>Display the visual content.</p>	<p>9 Shield Cover</p> <p>Protecting the electronic components from damage.</p>
<p>5 Housing</p> <p>It provides structural support and protection for the panel.</p>	

3.3 I/O Connectors

3.3.1 Touch Monitor Interface

A touch monitor typically incorporates a VGA, DP, DVI, HDMI, a power supply interface, and a USB interface for touch functionality. The specific interface combinations may vary across different models. For detailed information, please refer to the drawings, specifications, and physical object of the touch display model.

Although the examples provided below may not be exhaustive, they represent some of the most prevalent combinations of interface types.

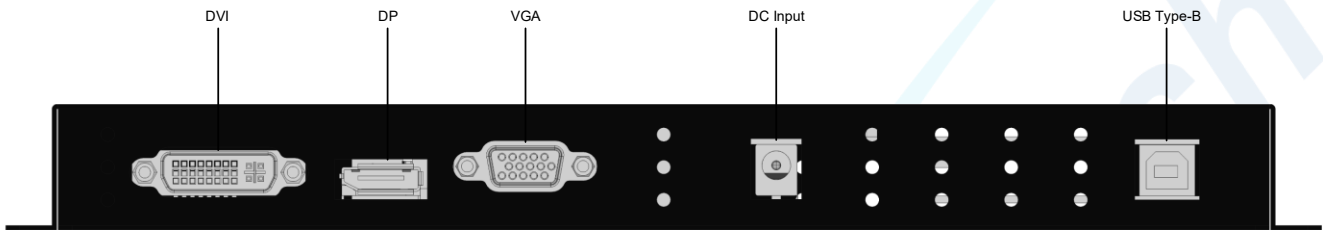

Fig 3 OTL227 Touch Monitor I/O Connector Diagram



Fig 4 OTL327 Touch Monitor I/O Connector Diagram

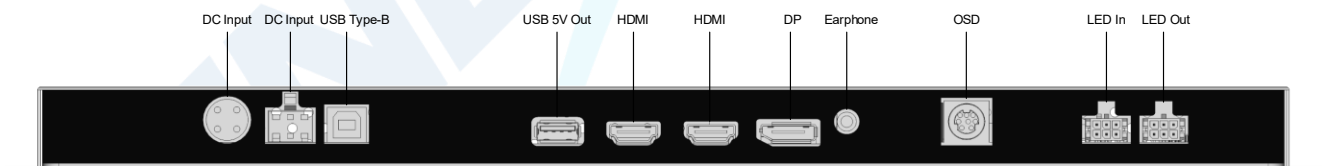

Fig 5 OTL437 Touch Monitor I/O Connector Diagram

Production Description



A HDMI Type-A connector is provided to connect the monitor to a computer.



A 15-pin VGA connector is provided to connect the monitor to a computer.



A DisplayPort connector is provided to connect the monitor to a computer.



A DVI connector is provided to connect the monitor to a computer.

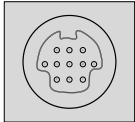

A Din 8 pin OSD connector is provided for connect remote OSD Button.



A 2.5mm center pin DC barrel jack connector is provided for power input.

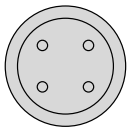

A 4pin connector is provided for power input.



A MX3.0-2*3 connector is provided for power input.



A USB 2.0 Type-B connector is provided for touch support.

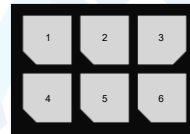

A 6-pin Molex connector is provided to connect LED strip and LED controller.

3.3.2 LED Strip Connector Interfaces and Definitions

The LED strip connector is located at the touch monitor end and is available with either a 6-pin Molex connector or a 4-pin Molex connector.

3.3.2.1 External Power Supply with Two Interfaces

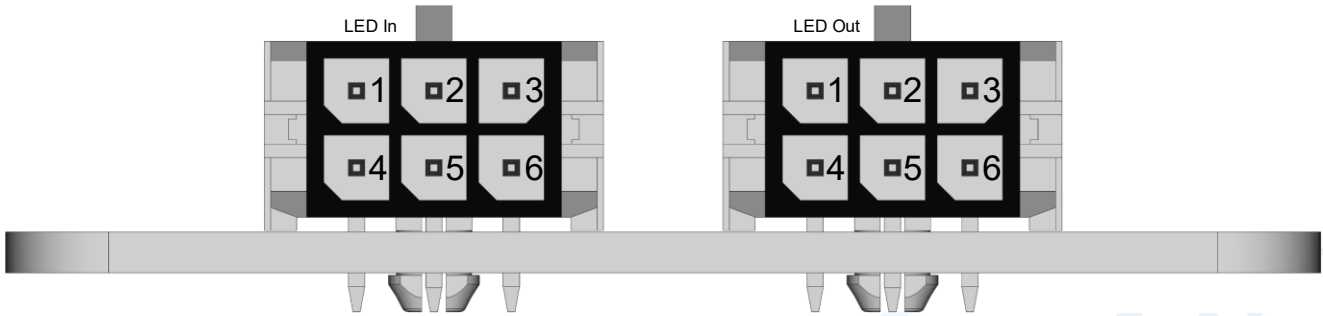

Two 6-pin LED strip connectors are appropriate for use with large touch monitors that are 12V powered and 27” or more.

Table 1 LED In

No.	PIN	Function Description
1	GND	Data & Power Grounding
2	NC	No connected
3	GND	Data & Power Grounding
4	12V	LED POWER SUPPLY, connect to “+12V”
5	DI	Control data signal input
6	12V	LED POWER SUPPLY, connect to “+12V”

Table 2 LED Out

No.	PIN	Function Description
1	GND	Data & Power Grounding
2	NC	No connected
3	GND	Data & Power Grounding
4	12V	LED POWER SUPPLY, connect to “+12V”
5	DO	Control data signal output
6	12V	LED POWER SUPPLY, connect to “+12V”

3.3.2.2 External Power Supply with Two Interfaces

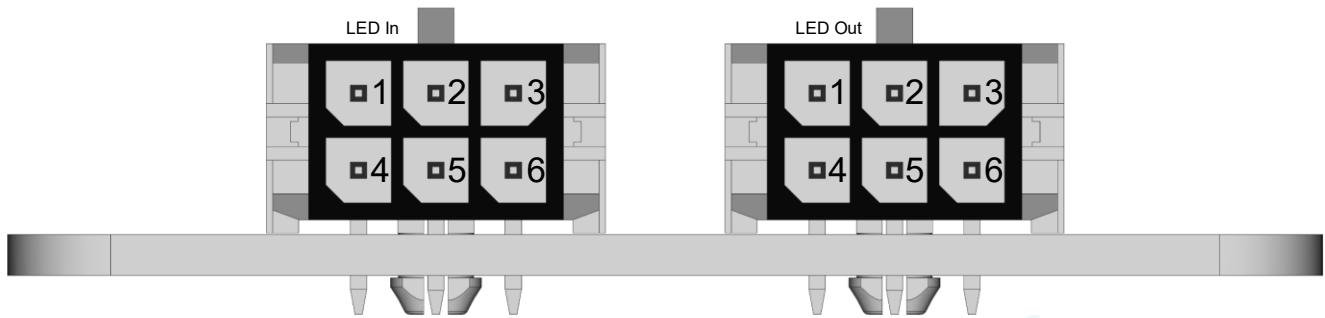

Two 6-pin LED strip connectors are appropriate for small to medium-sized touch monitors with an internal power supply solution, such as those measuring 24” or 27”.

Table 3 LED In

No.	PIN	Function Description
1	NC	No connected
2	DI	Control data signal input
3	NC	No connected
4	NC	No connected
5	NC	No connected
6	GND	Data & Power Grounding

Table 4 LED Out

No.	PIN	Function Description
1	NC	No connected
2	DO	Control data signal output
3	NC	No connected
4	NC	No connected
5	NC	No connected
6	GND	Data & Power Grounding

3.3.2.3 Single interface

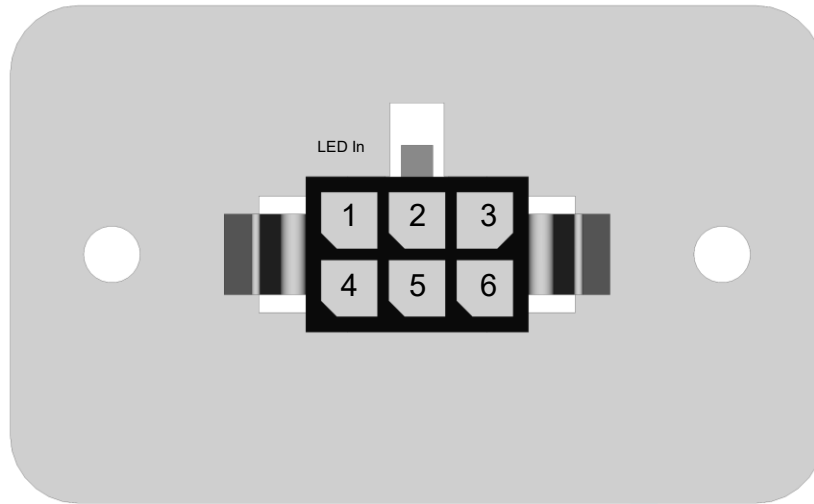

The single 6-pin LED strip connector is compatible with touch monitors that are 5V powered and have a size of 24" or less.

No.	PIN	Function Description
1	GND	Data & Power Grounding
2	DO	Control data signal output
3	5V	LED POWER SUPPLY, connect to "+5V"
4	GND	Data & Power Grounding
5	DI	Control data signal input
6	5V	LED POWER SUPPLY, connect to "+5V"

The single 6-pin LED strip connector is compatible with touch monitors that are 12V powered and have a size of 21.5" or more.

No.	PIN	Function Description
1	GND	Data & Power Grounding
2	DO	Control data signal output
3	GND	Data & Power Grounding
4	12V	LED POWER SUPPLY, connect to "+12V"
5	DI	Control data signal input
6	12V	LED POWER SUPPLY, connect to "+12V"

3.4 LED Strip Description

A LED strip is comprised of LEDs, PCB, connectors, heat dissipation systems, and housings, among other components. The LEDs are connected in parallel to achieve a more even illumination. The LEDs are the core components of the strip and are responsible for emitting visible light. The PCB is the principal components that support and connect the LEDs. They are integrated with electronic components, such as driver chips, resistors, and capacitors, which are used to control the brightness and color of the LEDs. The LED strip is utilized to regulate the brightness and color of the LEDs.

It can be classified into two categories: an ordinary RGB LED strip and an aRGB LED strip, which are distinguished based on the actual application scenario.

3.4.1 RGB LED strip

RGB refers to the three primary colors: red, green, and blue. These three primary colors can be combined in various ways to create an infinite number of secondary colors. RGB lamps operate based on the principle of mixing the three primary colors, which is known as tricolor mixing. Typically, RGB lighting systems comprise a combination of red, green, and blue light-emitting diodes (LEDs). Each LED is equipped with a dedicated driver circuit that regulates its brightness. By modulating the brightness and mixing ratio of each LED, the desired color output can be attained.

With non-addressable RGB, whatever commands you provide to the LED's will affect every LED on the circuit. Each LED chip is not individually controlled. So, if you want one LED to be Blue, then every LED will be Blue. If you want one LED to be off, then all the LED's will be off.

3.4.2 Addressable RGB LED strip

Addressable RGB (aRGB) is a modern LED technology that changes how we experience light and color. Unlike regular RGB, aRGB enables individual control of each LED, opening up endless possibilities for dynamic and personalized lighting effects.

With addressable RGB, each one of these individual LED chips can be programmed on it's own. So, you can individually control what colors are showing up (Red, Green, Blue, or White). You can also control that individual chip's brightness, whether it's on or off, and other aspects of it's lighting as well.

Well, you have a lot more customization options when it comes to addressable RGB LED's. You are able to individually control the effects for each individual LED.

3.4.3 Break-point Continuous Transmission

The LED strip is equipped with a break-point continuous transmission function, which ensures that a malfunction of the LED strip is limited to a single LED that does not illuminate. This isolated failure will not result in the non-illumination of other LEDs and will not affect the overall functionality of the light bar.





3.5 Touch Functions

Capacitive touch monitors are capable of supporting multi-touch functionality of 10 points or more, which enables a range of actions such as smooth zooming, flicking, rotating, swiping, dragging, pinching, pressing, double-tapping, and other functions.

The touch monitor is factory-calibrated and does not require manual calibration. Unless the input video is not fully scaled to the native resolution, or the touch experience needs to be adjusted for a specific user.

Our Touch Monitor supports various gesture operations such as tapping and swiping. Please refer to the following gesture table for more details:

Table 5 Touch Gesture Descriptions

Gestures	Name	Type	Descriptions
	Tap	Static Gestures	Single Finger (Pads) to Touch and Swipe the Screen
	Multi Tap	Gesture Operations	Multiple Fingers (Pads) to Touch and Swipe the Screen
	Swipe	Gesture Operations	Moving a finger (Pads) across the screen
	Other	Gesture Operations	Supports Touch Operations on Different Platforms

Note: The above gestures are based on the Windows Universal Platform for the host operating system, as well as support from certain applications. The icons are for reference only, and the actual display on the touchscreen may vary depending on the specific model.

MOUNTING AND OPERATION INSTRUCTIONS

This section presents an examination of structural installation design and the presentation of concise installation methods.

4 MOUNTING AND OPERATION INSTRUCTIONS

4.1 Mounting Design

The LED-Framed touch monitor is designed for the gaming industry to ensure universal mounting in gaming machines.

The central positioning of the VESA holes on the back of the display evenly distribute its weight for secure mounting. They are also designed for easy installation and maintenance.

4.2 Usage

The LED-framed touch monitor offer users the ability to meet their personalized scene application needs through the collocation of different product combinations.

4.2.1 A Touch Monitor



Fig 6 One touch monitor

4.2.2 Combo Touch Monitor

4.2.2.1 Two Touch Monitors (27" or 32")



Fig 7 a combo touch monitor (two touch monitors)

4.2.2.2 Three Touch Monitors (27" or 32")

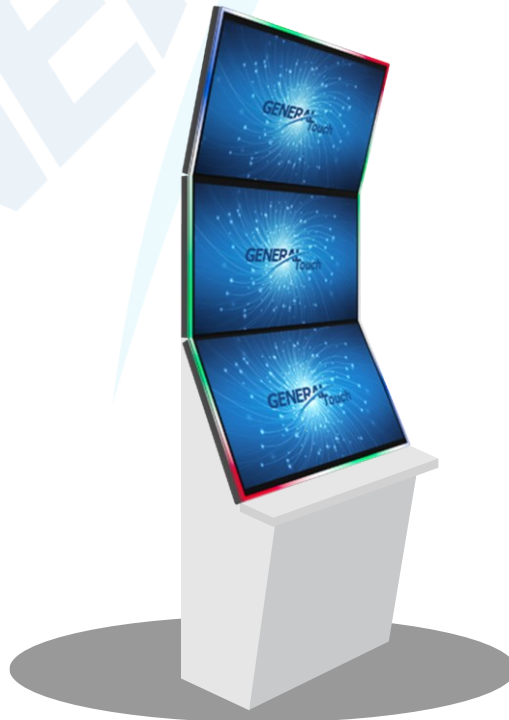

Fig 8 a combo touch monitor (three touch monitors)

4.2.2.3 Multiple non-identical touch monitors

The image illustrates an example of a circular touch monitor, which is used as a topper.



Fig 9 Multiple non-identical touch monitors

4.3 Packing and Unpacking

After taking our product out of the packaging box, first inspect the appearance, and then read the specifications and user manual one by one. The steps to open the device packaging are as follows:

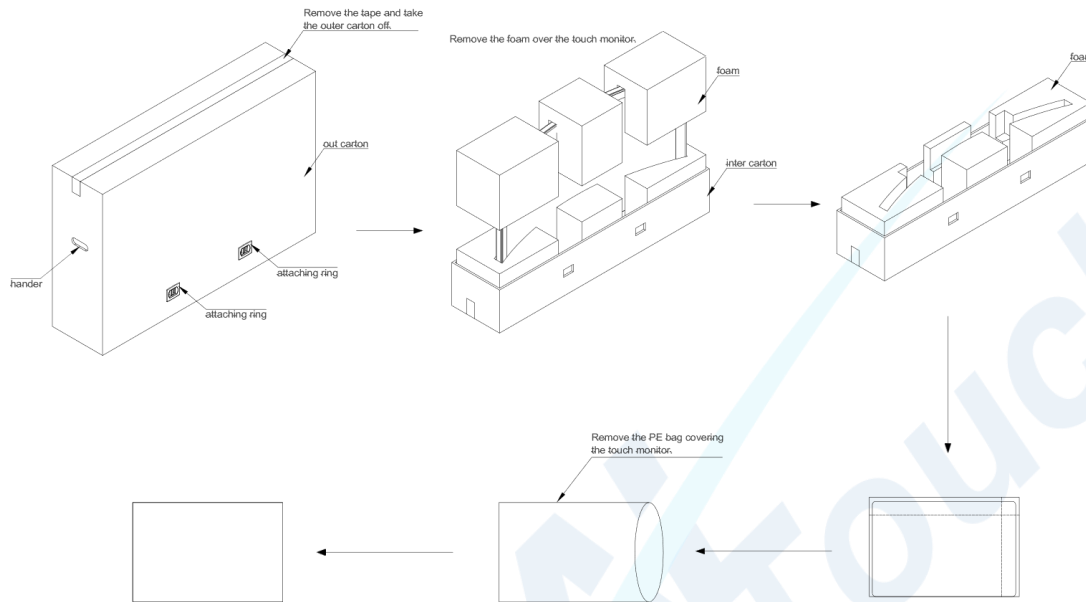

Fig 10 Standard Unboxing Process

Unboxing precautions:

- ◆ Do not discard the original packaging box.
- ◆ Check the goods list against your order to ensure completeness.
- ◆ Keep the documents that come with the device, as they contain important information about the device and how to use it.
- ◆ Check for any obvious transportation damage inside the packaging.

If you find any transportation damage or discrepancies between the packaging and the order, please inform General Touch's sales or after-sales department.

4.4 Mounting type

The LED-Framed touch monitor is designed for the gaming industry to ensure universal mounting in gaming machines. In the majority of cases, the installation is integrated into the customer's cabinet. The following section presents a selection of flat and curved touch displays, accompanied by an illustration of a floor-mounted stand as a representative example of the installation. It should be noted that the floor mount stand is not included in the original purchase.

4.4.1 Flat Touch Monitor

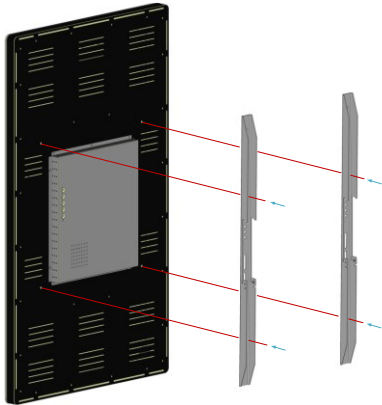

The two brackets affixed to the floor mount stand should be removed and secured to the VESA holes in the touch monitor with screws. Subsequently, the touch monitor is to be mounted to the floor mount stand.

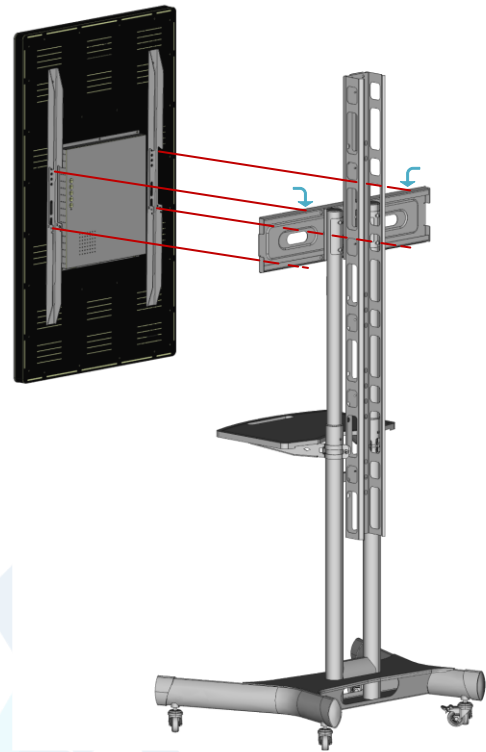

Fig 11 The VESA bracket is mounted

Fig 12 The Floor Mount Stand is mounted



Fig 13 Right side lateral view

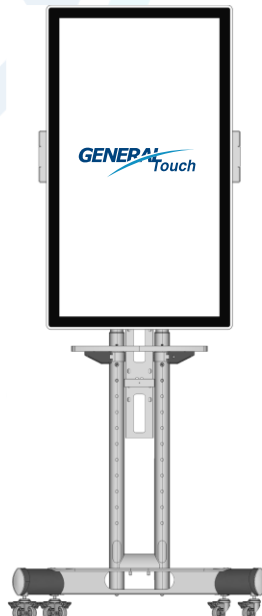
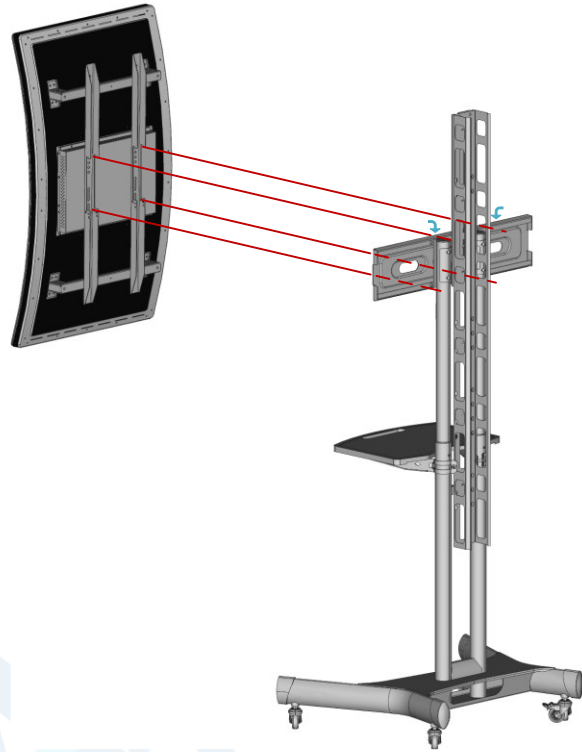
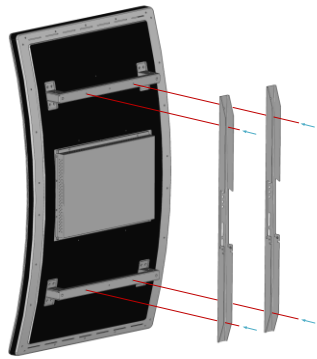

Fig 14 Front view



Fig 15 Left side lateral view

4.4.2 Curved Touch Monitor



The two brackets affixed to the floor mount stand should be removed and secured to the VESA holes in the touch monitor with screws. Subsequently, the touch monitor is to be mounted to the floor mount stand.

Fig 16 The VESA bracket is mounted

Fig 17 The Floor Mount Stand is mounted



Fig 18 Right side lateral view

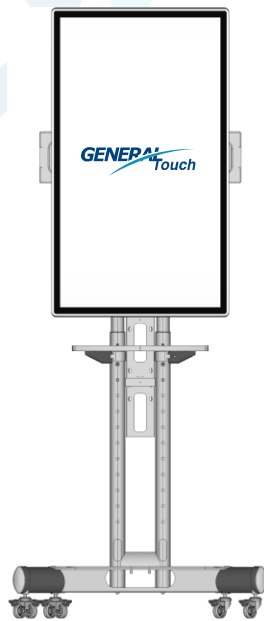

Fig 19 Front view



Fig 20 Left side lateral view

INSTRUCTIONS FOR USE

This section presents the instructions for the utilization of the LED controller.

GENERATOR TOUCH

5 INSTRUCTIONS FOR USE

5.1 LED Controller

The LED controller kits typically comprises the LED controller, power adapter, and connecting cable, among other components. Its primary function is to illuminate the LED strip and configure the various LED strip effect modes.

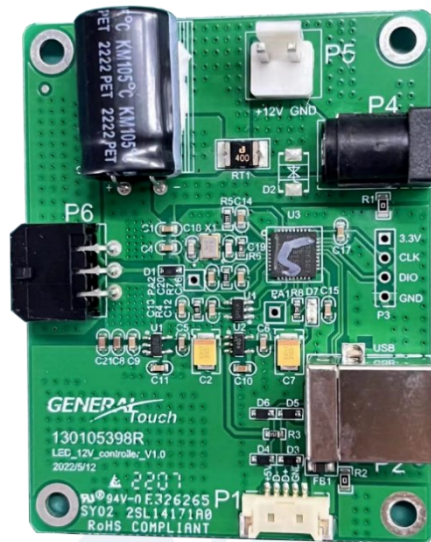
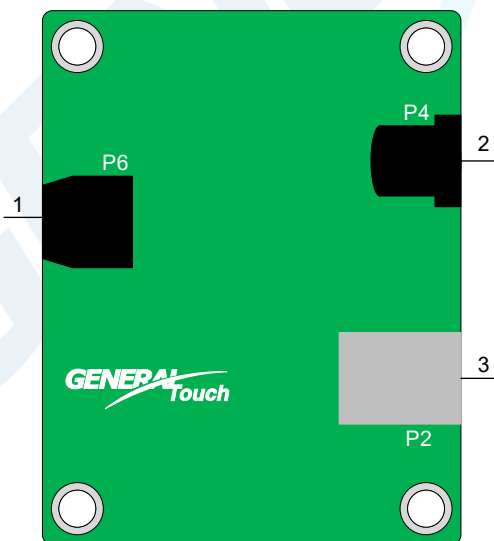

Fig 21 LED controller

5.1.1 I/O Connector and define

The following table presents the LED Controller interface and its associated definition.



- | | | |
|---|----|--|
| 1 | P6 | LED
For touch monitor's LED strips. |
| 2 | P4 | DC Jack
DC 12V input. |
| 3 | P2 | USB Type-B
To connected PC. |

Fig 22 Schematic of the LED Controller Interface

5.1.2 How to use LED Controller

To facilitate customer control over the LEDs, GT provides protocols and controllers for customers to choose from. The LED controllers can be embedded or external, and it also supports customer-supplied controllers. The lighting effects offer dozens of standard modes and can be customized to meet specific customer requirements.

5.1.2.1 Functional Mode Description

The LED controller has been programmed with a firmware that is preset at the factory with a variety of modes, including those for running lights and solid colors.

What's more, it has 32 different program pattern inside which can help you test before installation.

5.1.3 LEDBarTool Instructions

The LED controller tool, "gtledbartool", enables the user to set up the light strip, with settings including the number of LEDs, color, and brightness. Additionally, there are built-in preset modes, including running lights, gradient, multi-color switching, and others. For detailed configuration and usage instructions, please refer to the "CS-0003 LEDBarTool User Manual V2.0", written by General Touch.

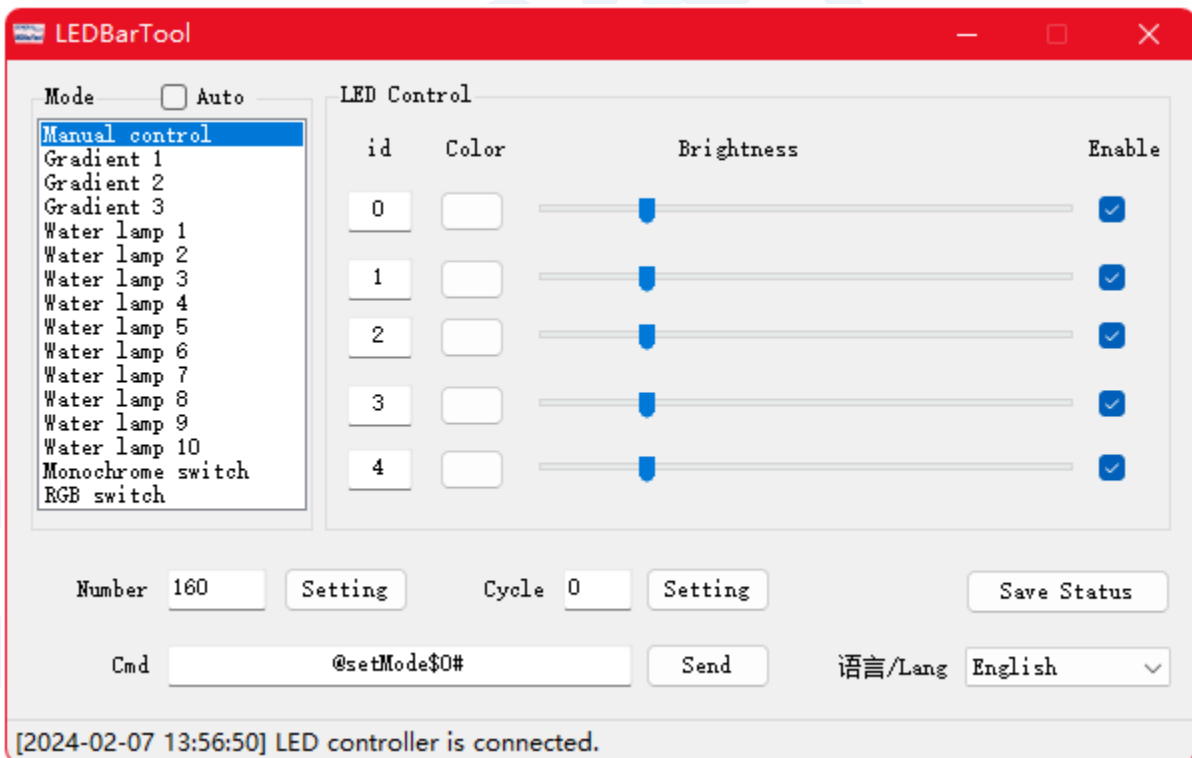

Fig 23 The "Manual Control" Configuration

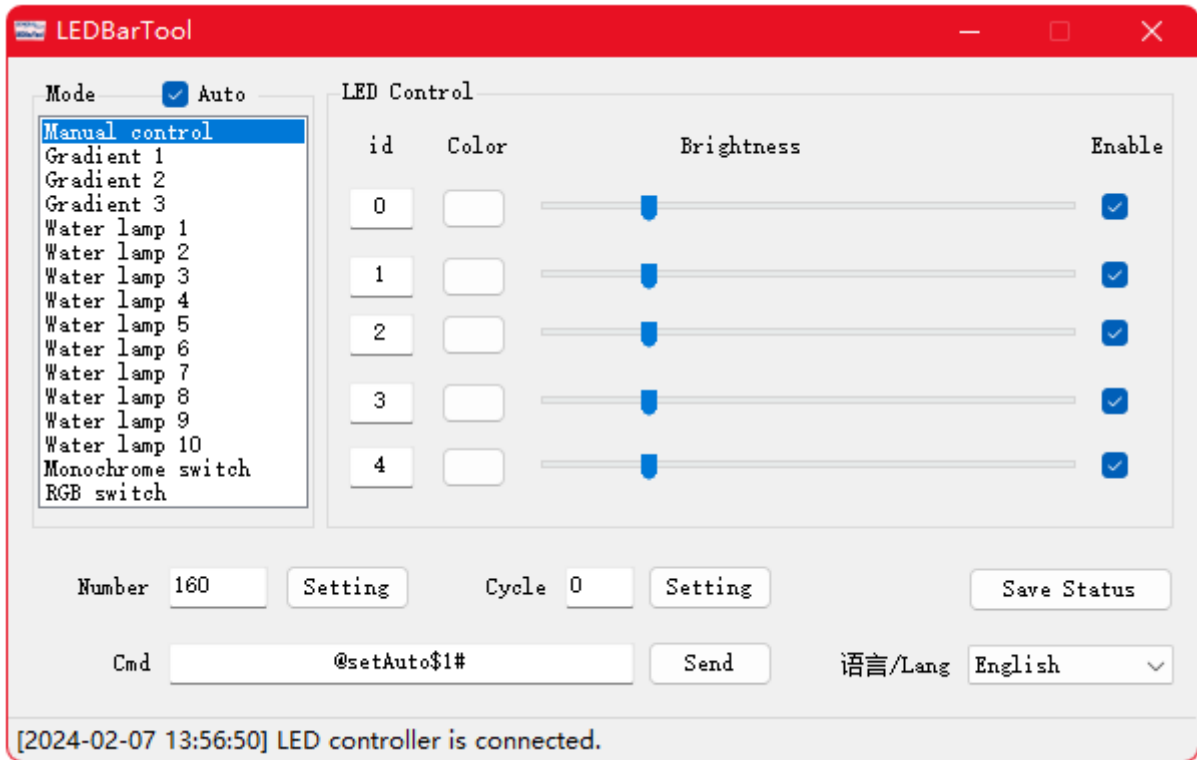

Fig 24 The "Auto Control" Configuration

5.1.4 Extension

General Touch offers an SDK based on the Windows and Linux, thereby enabling users to achieve a greater degree of personalisation and functionality. The SDK allows the user to implement additional color changes and control modes.

5.2 The LED Controller and LED Strip Connection

The components of a LED strip kits utilized in a touch monitor typically encompass a LED strip, a LED controller, a LED strip Connector board, a LED strip connection cable, and LED strip configuration tools. The connection cable, which is utilized to connect the LED strip and the LED controller, is typically 1.0 meters in length.

In the event that the customer elects to utilize a LED controller of their own choosing, the length of the connection cable must be restricted to a maximum of 2.0 meters to prevent any adverse effects on the functionality of the LED strip.

It should be noted that the PCs indicated in the LED strip connection diagrams presented below are not provided by General Touch.

5.2.1 Single Touch Monitor

In the event that a single touch monitor is being utilized, it is only necessary to consult the following figure. The connection cable should then be employed to connect the LED controller to the LED strip connector port on the touch monitor side. Finally, the USB cable should be utilized to connect the LED controller to the PC.

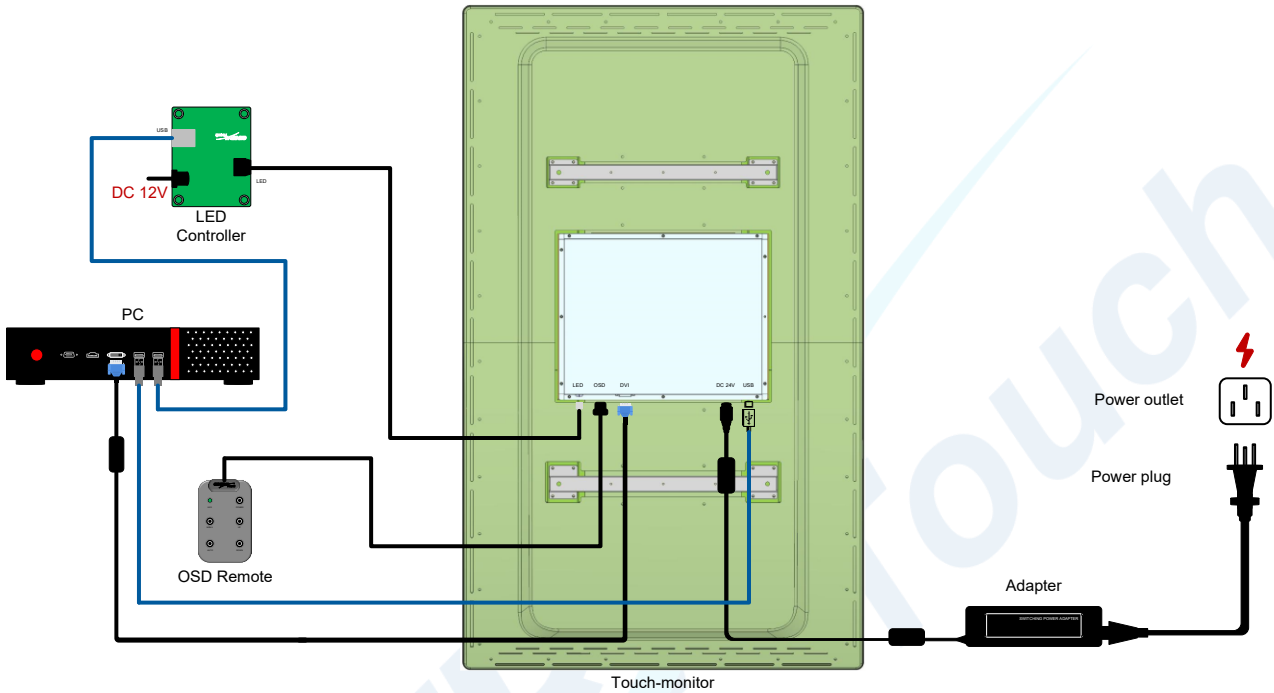

Fig 25 The connection between the touch monitor and the LED controller

5.2.2 Combo Touch Monitor

5.2.2.1 Regular

The following schematic pertains to a multiple touch-monitor LED strip in series solution, which represents our conventional touch-screen LED strip connection. This solution is characterized by simplicity and rapidity of implementation. It is important to note that the number of series connections of the touch monitor or LED strip must be aligned with the maximum output power supported by the LED controller. Otherwise, this may result in an adverse impact on the display effect of the LED strip.

To illustrate, the LED controller initially establishes a connection between the LED In of one touch monitor and the LED Out of another touch monitor. This process is then repeated for each subsequent touch monitor, thus enabling the connection of multiple touch monitors in series.

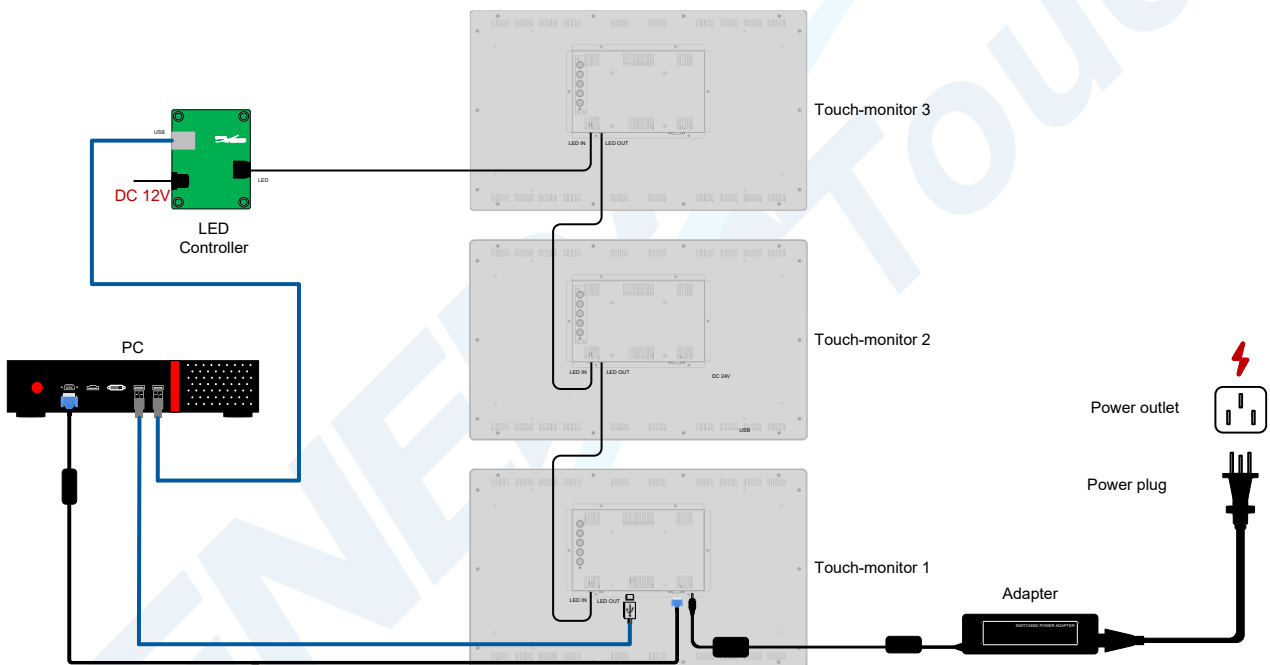

Fig 26 The connection between the touch monitor and the LED controller 1

5.2.2.2 Customization

An alternative method for connecting a LED controller to a touch monitor LED strip is illustrated in the subsequent schematic. This configuration is suitable for a touch monitor with a single LED strip connector port.

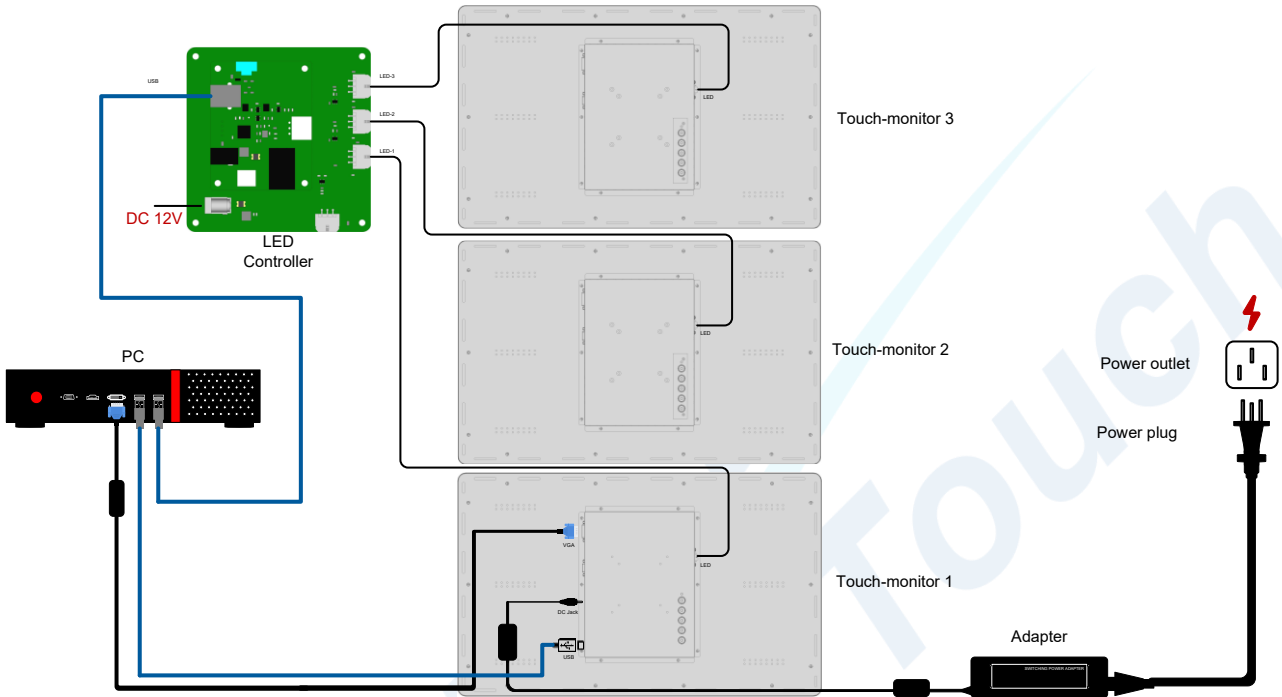

Fig 27 The connection between the touch monitor and the LED controller 2

5.2.3 Powering the LED strips

Once the LED controller is connected to the LED strip of the touch monitor, the user may then proceed to power the LEDs. Furthermore, the software allows for the switching of multiple modes.

5.2.4 Others

It is possible to drive both the LED strip of the touch monitor and the LED strip of the customer's cabinet by utilising the same LED controller. This can be achieved by customising the LED controller and the firmware. In the event that the user elects to utilize multiple LED controllers to drive the LED strip and the cabinet LED strip in a discrete manner and to establish a connection between them and the same PC, it will be necessary to modify the PID of the LED controllers. This alteration will permit the PC to recognize the LED controllers and will enable the LED controllers to receive commands from the software.

OSD MENU SETUP

This section presents an overview of the OSD menu interface of the touch monitor, along with an examination of the methods used to adjust and operate its parameters.

6 OSD MENUS SETUP

6.1 OSD buttons description

The OSD board is typically utilized to modify the screen brightness, contrast, and other parameters of the touch monitor, thereby ensuring the touch monitor's suitability for a multitude of application scenarios.

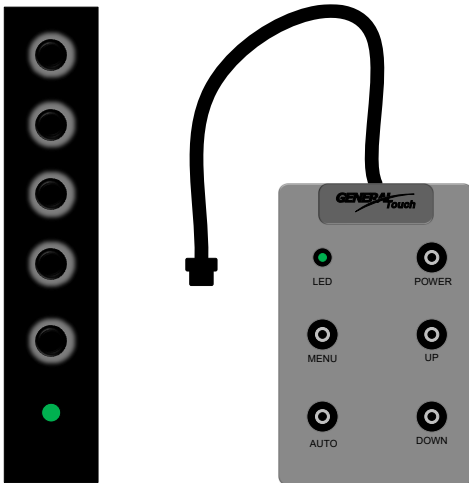
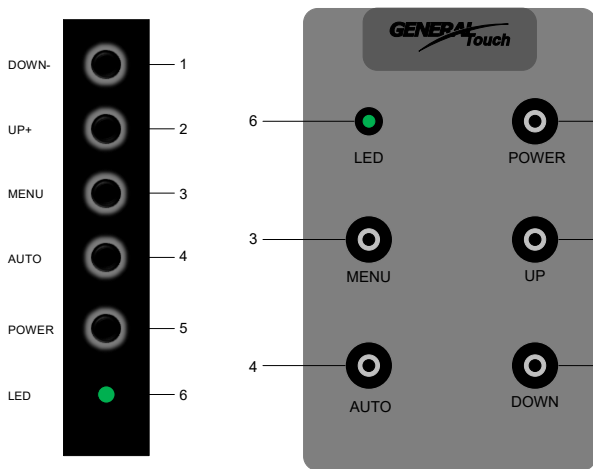

Fig 28 Integrated and external OSD

To adjust the screen and parameters of the Touch Monitor, it is necessary to understand the options and functions provided in the OSD menu (On-Screen Display), as well as how to use them. You can operate the OSD menu using the OSD Remote or the buttons located on the back of the Touch Monitor.

Note: It is important to familiarize yourself with the functions of each button, regarding the explanation of OSD Remote control button functions, in order to successfully complete the OSD parameter settings. The following illustrations are for reference only. Different models may have slight differences in their display interface and operational methods (workflow), so please refer to the actual device for accurate information.

6.1.1.1 OSD board's Button functions and locations



Touch Monitor OSD Remote Description

	Touch Monitor OSD Remote Description
1	DOWN Adjustment button, Adjust Down/Left
2	UP Adjustment button, Adjust Up/Right
3	Menu Menu Button, confirm the selection
4	AUTO Auto-adjust screen parameters, Exit/Return
5	POWER Power button, Turn ON/ OFF

Fig 29 OSD Remote Control Buttons Distribution

6 Indicator Light

Indicates the working status of the touch monitor



Off, not connected to power



Green, normal operation



Red, connected to power but in a non-working state

6.2 OSD Menu Overview

The various models of touch screen and their corresponding OSD (on-screen display) settings menu interface will differ. The following list provides a few common examples for reference; the specific settings should be consulted in the actual interface of the corresponding model. It should be noted that the parameter values in the following chart do not represent the default settings.

6.2.1 User Interface 1

The OSD menu interface is compatible with the bigger, curved touch monitors, including the OML24D, OTL245, OTL327.

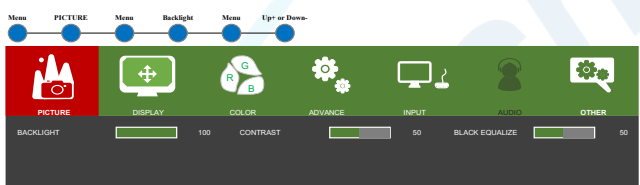
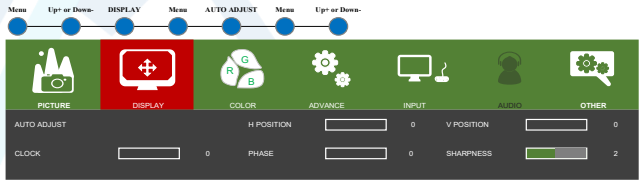
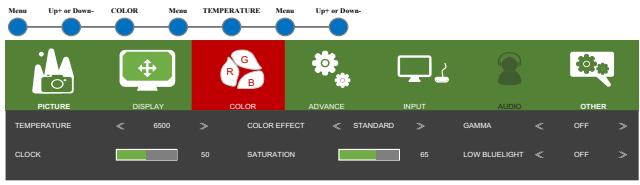
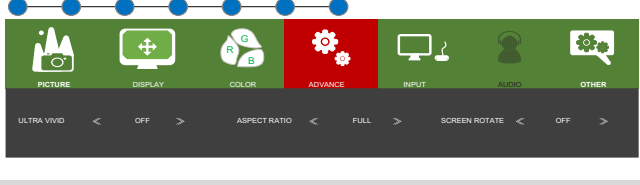
<p>BACKLIGHT: 0 ~ 100 CONTRAST: 0 ~ 100 BLACK EQUALIZE: 0 ~ 100</p>	 <p>Fig 30 "PICTURE" Menu</p>
<p>AUTO ADJUST: H POSITON: 0 ~ 100 V POSITON: 0 ~ 100 CLOCK: 0 ~ 100 PHASE: 0 ~ 100 SHARPNESS: 0 ~ 2.4</p>	 <p>Fig 31 "DISPLAY" Menu</p>
<p>TEMPERATURE: 9300, 7500, 6500, 5800 COLOR EFFECT: STANDRAD, USER GAMMA: OFF, 1.8, 2.0, 2.2 CLOCK: 0 ~ 100 SATURATION: 0 ~ 100 LOW BLUELIGHT: OFF, ON</p>	 <p>Fig 32 "COLOR" Menu</p>
<p>ULTRA VIVID: OFF, ON ASPECT RATIO: FULL, 16:9, 4:3 SCREEN ROTATE: OFF, 90, 180</p>	 <p>Fig 33 "ADVANCE" Menu</p>

OSD Menu Setup

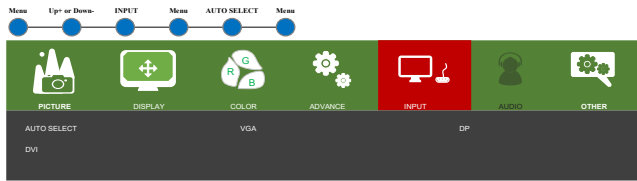
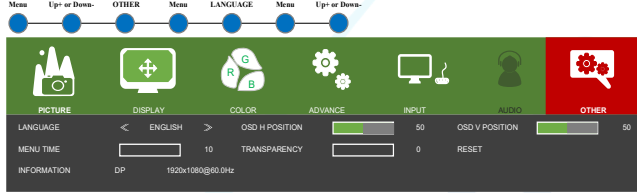
<p>AUTO SELECT, VGA, DP, DVI</p>	 <p>Fig 34 "INPUT" Menu</p>
<p>LANGUAGE: ENGLISH, 简体中文…… OSD H POSITION: 0 ~ 100 OSD V POSITION: 0 ~ 100 MENU TIME: 0 ~ 100 TRANSPARENCY: 0 ~ 100 RESET</p>	 <p>Fig 35 "OTHER" Menu</p>

6.2.2 User Interface 2

The OSD menu interface is compatible with the bigger, curved touch monitors, including the OTL437, OTJ497, OTC437, OTC497.

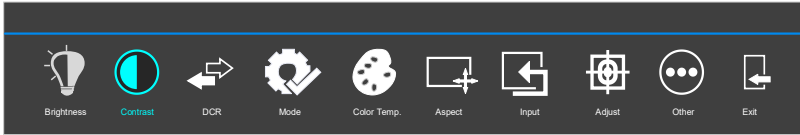

OSD Primary Menu

After pressing the menu button (MENU), the OSD menu will open. In this menu, you can use the buttons, such as (UP+) or (DOWN-), to navigate horizontally and vertically.



6.2.2.1 Secondary Menu

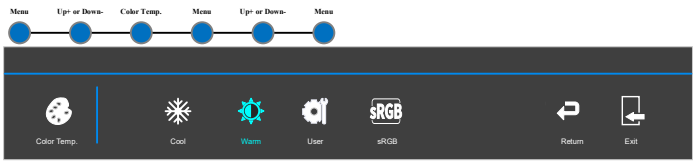
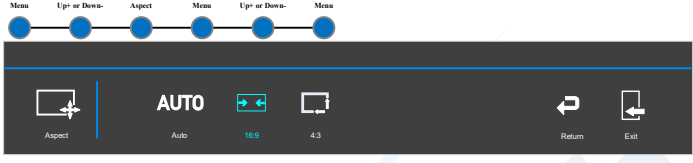
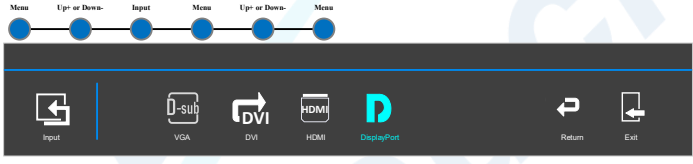
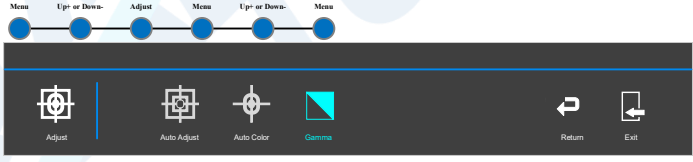
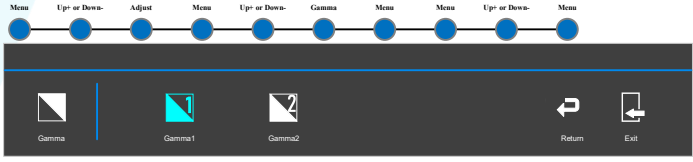
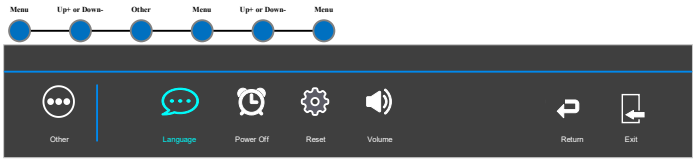

<p>Brightness: 0 ~ 100</p>	<p>Fig 36 "Brightness" Menu</p>
<p>Contrast: 0 ~ 100</p>	<p>Fig 37 "Contrast" Menu</p>
<p>DCR: On, Off</p>	<p>Fig 38 "DCR" Menu</p>
<p>Standard, Movie, FPS, RTS, Eye Saver</p>	<p>Fig 39 "Mode" Menu</p>

<p>Cool, warm, user, sRGB</p>	 <p>The menu shows navigation options (Menu, Up/Down) and a list of color temperature settings: Color Temp., Cool, Warm, User, sRGB, Return, and Exit. The 'Color Temp.' option is currently selected.</p> <p>Fig 40 "Color Temp." Menu</p>
<p>Aspect: Auto, 16:9, 4:3</p>	 <p>The menu shows navigation options (Menu, Up/Down, Adjust) and aspect ratio settings: Aspect, AUTO, 16:9, 4:3, Return, and Exit. The 'Aspect' option is currently selected.</p> <p>Fig 41 "Aspect" Menu</p>
<p>VGA, DVI, HDMI, DisplayPort</p>	 <p>The menu shows navigation options (Menu, Up/Down, Input) and input source settings: Input, VGA, DVI, HDMI, DisplayPort, Return, and Exit. The 'Input' option is currently selected.</p> <p>Fig 42 "Input" Menu</p>
<p>Auto Adjust, Auto color, Gamma. Upon selection of the "Gamma" option, the current setting is advanced to the subsequent level of the menu.</p>	 <p>The menu shows navigation options (Menu, Up/Down, Adjust) and adjustment settings: Adjust, Auto Adjust, Auto Color, Gamma, Return, and Exit. The 'Adjust' option is currently selected.</p> <p>Fig 43 "Adjust" Menu</p>
<p>Gamma: Gamma1 and Gamma2</p>	 <p>The menu shows navigation options (Menu, Up/Down, Adjust, Gamma) and gamma settings: Gamma, Gamma1, Gamma2, Return, and Exit. The 'Gamma' option is currently selected.</p> <p>Fig 44 "Gamma" is in the "Adjust" submenu</p>
<p>Language: English, 简体中文…… Power Off Reset volume</p>	 <p>The menu shows navigation options (Menu, Up/Down, Other) and other system settings: Other, Language, Power Off, Reset, Volume, Return, and Exit. The 'Other' option is currently selected.</p> <p>Fig 45 "Other" Menu</p>

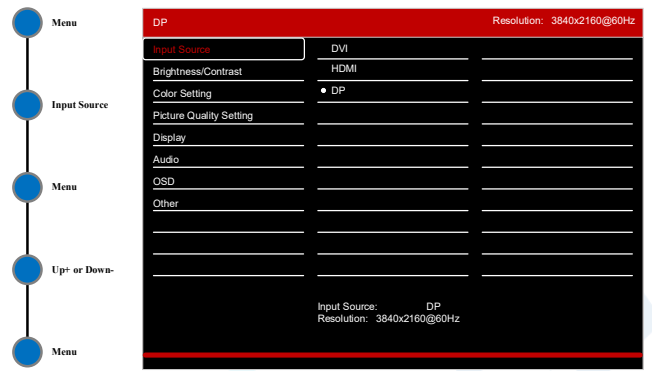
6.2.3 User Interface 3

The OSD menu interface is compatible with the bigger, curved touch monitors, including the OTC327.

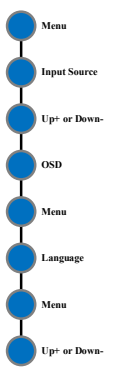
<p>DVI, HDMI, DP</p>	 <p>The screenshot shows the 'Input Source' menu. The left sidebar has 'Input Source' selected. The main area shows a list of input sources: DVI, HDMI, DP (selected), and Other. At the bottom, it displays 'Input Source: DP' and 'Resolution: 3840x2160@60Hz'.</p> <p>Fig 46 "Input Source" Menu</p>
<p>Brightness: 0~100 Contrast: 0~100 DCR: On, Off</p>	 <p>The screenshot shows the 'Brightness/Contrast' menu. The left sidebar has 'Brightness/Contrast' selected. The main area shows sliders for 'Brightness' and 'Contrast', and a 'DCR' (Dynamic Contrast Ratio) toggle. At the bottom, it displays 'Input Source: DP' and 'Resolution: 3840x2160@60Hz'.</p> <p>Fig 47 "Brightness/Contrast" Menu</p>
<p>Gamma: 1.8, 2.0, 2.2, 2.4, 2.6 Picture Mode: Color Temperature: User, Cool, Warm Hue: 0~100 Saturation: 0~100</p>	 <p>The screenshot shows the 'Color Setting' menu. The left sidebar has 'Color Setting' selected. The main area shows sliders for 'Gamma', 'Picture Mode', 'Color Temperature', 'Hue', and 'Saturation'. At the bottom, it displays 'Input Source: DP' and 'Resolution: 3840x2160@60Hz'.</p> <p>Fig 48 "Color Setting" Menu</p>

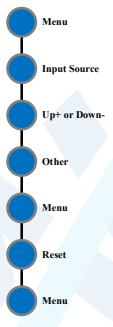
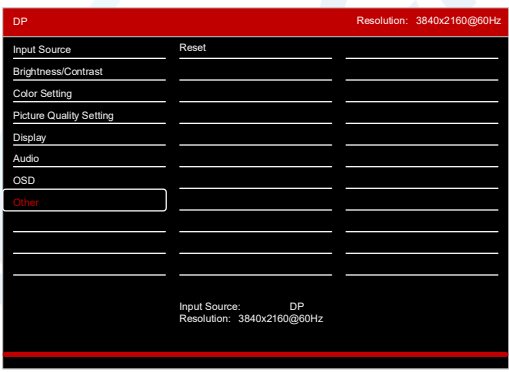
<p>Language: English, 简体中文, Русский, Español, Français, Português……</p> <p>OSD H-Position: 0~100</p> <p>OSD V-Position: 0~100</p> <p>OSD Transparency: 0, 25, 50, 75, 100</p> <p>OSD Time Out: 0~100</p> <p>OSD Rotation: 0, 90, 180</p>	 
<p>Fig 52 “OSD” Menu</p>	
<p>Reset</p>	 
<p>Fig 53 “Other” Menu</p>	

6.2.4 User Interface 4

The OSD menu interface is compatible with the smaller, curved touch monitors, including the OTC247, OTC245, and OTC277.

6.2.4.1 Picture Adjustment

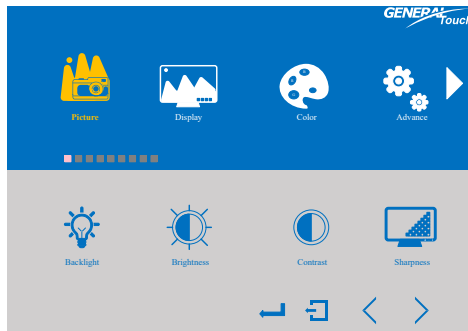

After pressing the menu button (MENU), the OSD menu will open. In this menu, you can use the buttons on the back, such as (UP+) or (DOWN-), to navigate horizontally and vertically. Press the menu button (MENU) again to select the highlighted menu item and enter the "Picture" menu.

The "Picture" menu provides the following setting options: Backlight, Brightness, Contrast, Sharpness.

<p>The adjustment range for Backlight: 0~100</p>	<p>Fig 54 Backlight in the "Picture" Menu</p>
<p>The adjustment range for Brightness: 0~100</p>	<p>Fig 55 Brightness in the "Picture" Menu</p>

The adjustment range for Contrast: 0~100

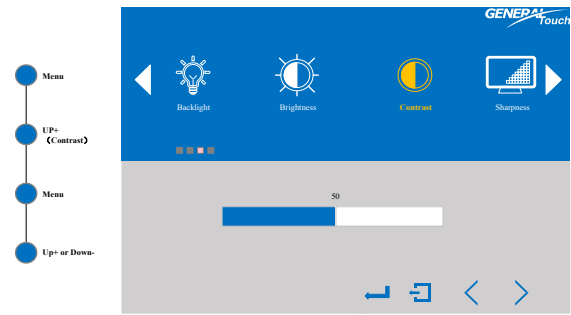

Fig 56 Contrast in the "Picture" Menu

The adjustment range for Sharpness: 0~2.4

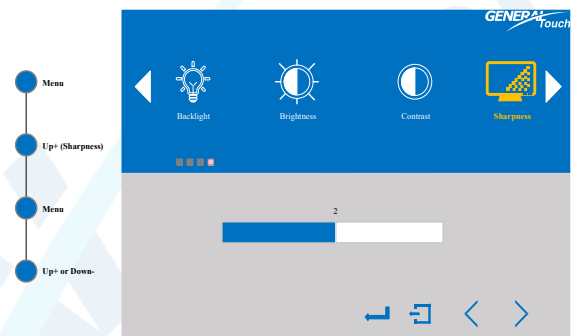
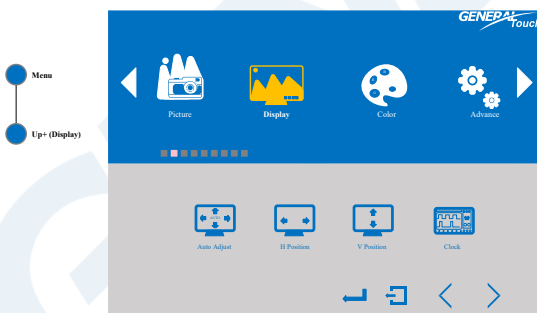

Fig 57 Sharpness in the "Picture" Menu

6.2.4.2 Display Adjustment



After pressing the menu button (MENU) mentioned above, the OSD menu will open. In this menu, you can use the buttons on the back, such as (UP+) or (DOWN-), to navigate horizontally. Press the menu button (MENU) again to select the highlighted menu item and enter the "Display" menu.

The "Display" menu provides the following setting options: Auto Adjust, H Position, V Position, Clock, Phase.

Auto Adjust state

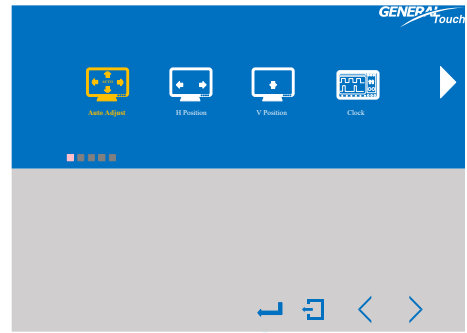

Fig 58 Auto Adjust state in the "Display" Menu

The adjustment range for H Position: 0~100

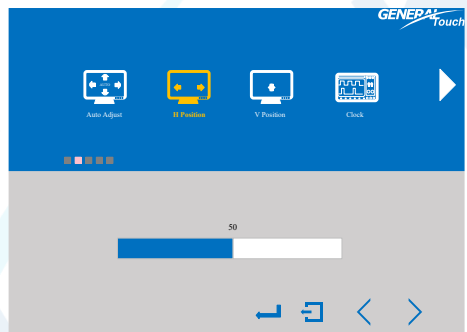
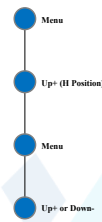

Fig 59 H Position in the "Display" Menu

The adjustment range for V Position: 0~100

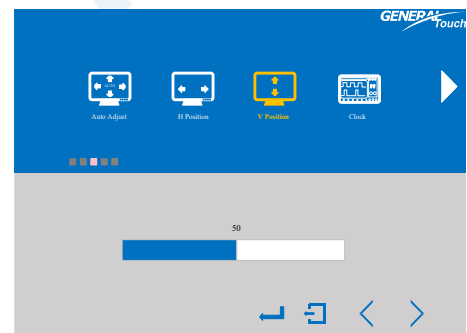
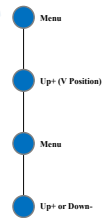

Fig 60 V Position in the "Display" Menu

The adjustment range for Clock: 0~100

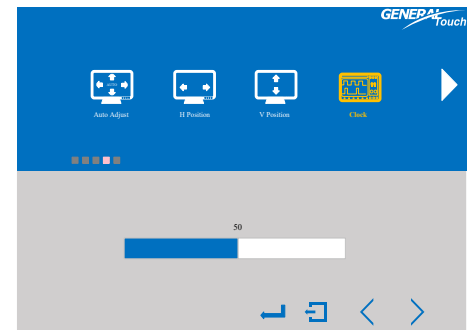
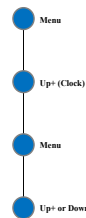

Fig 61 Clock in the "Display" Menu

The adjustment range for Phase: 0~100

- Menu
- Up+ (Phase)
- Menu
- Up+ or Down-

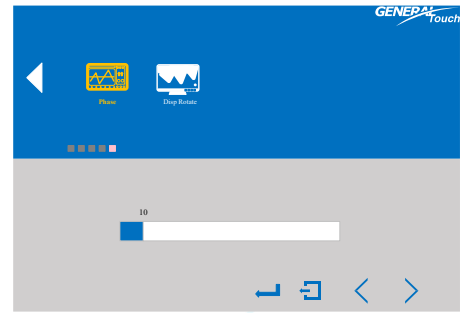
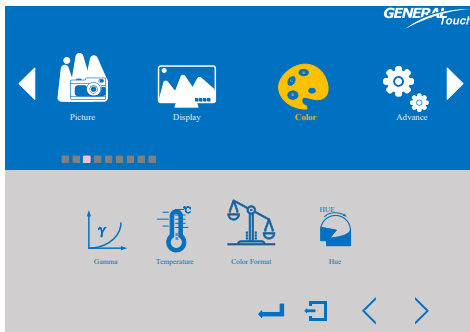

Fig 62 Phase in the "Display" Menu

6.2.4.3 Color Adjustment

- Menu
- Up+ (Color)



After pressing the menu button (MENU) mentioned above, the OSD menu will open. In this menu, you can use the buttons on the back, such as (UP+) or (DOWN-), to navigate horizontally. Press the menu button (MENU) again to select the highlighted menu item and enter the "Color" menu.

The "Color" menu provides the following setting options: Gamma, Temperature, Color Format, Hue.

Gamma optional: OFF, 1.8, 2.0, 2.2

- Menu
- Gamma
- Menu
- Up+ or Down-

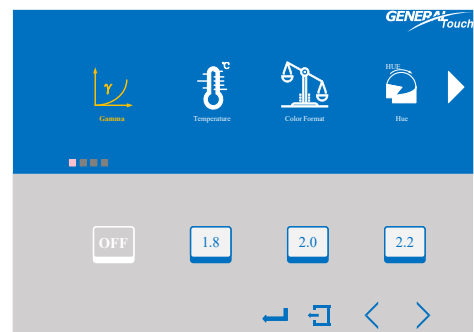

Fig 63 Gamma in the "Color" Menu

Temperature optional: 9300, 7500, 6500, 5800



Fig 64 Temperature in the "Color" Menu

Color Format optional: RGB, YUV

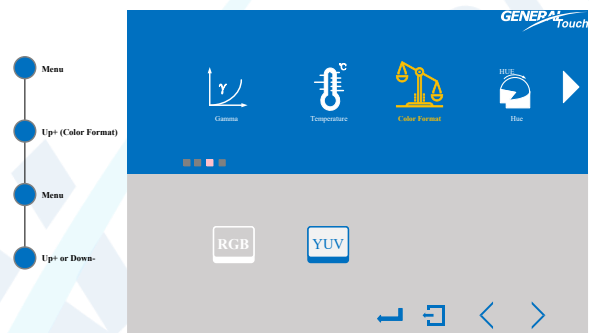

Fig 65 Color Format in the "Color" Menu

The adjustment range for Hue: 0~100

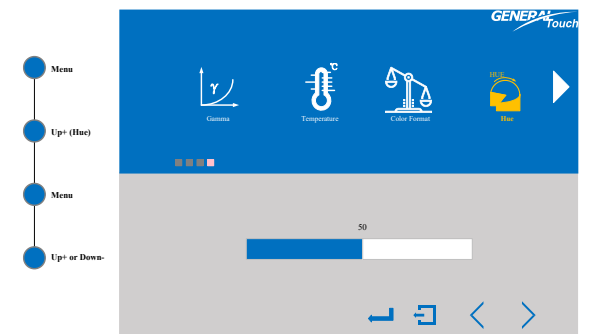
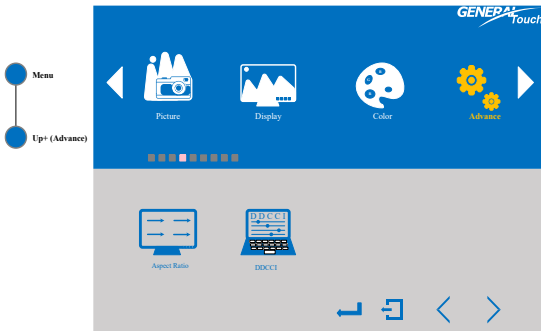

Fig 66 Hue in the "Color" Menu

6.2.4.4 Advance



After pressing the menu button (MENU) mentioned above, the OSD menu will open. In this menu, you can use the buttons on the back, such as (UP+) or (DOWN-), to navigate horizontally. Press the menu button (MENU) again to select the highlighted menu item and enter the "Advance" menu.

The "Advance" menu provides the following setting options: Aspect Ratio, DDCCI.

<p>Aspect Ratio optional: Full, 16:9, 4:3, 5:4</p>	<p>The screenshot shows the sub-menu for Aspect Ratio. It features four buttons labeled FULL, 16:9, 4:3, and 5:4. The 16:9 button is highlighted with a yellow border. Navigation arrows are at the bottom.</p> <p>Fig 67 Aspect Ratio in the "Advance" Menu</p>
<p>DDCCI optional: ON, OFF</p>	<p>The screenshot shows the sub-menu for DDCCI. It features two buttons labeled ON and OFF. The OFF button is highlighted with a yellow border. Navigation arrows are at the bottom.</p> <p>Fig 68 DDCCI in the "Advance" Menu</p>

6.2.4.5 Input

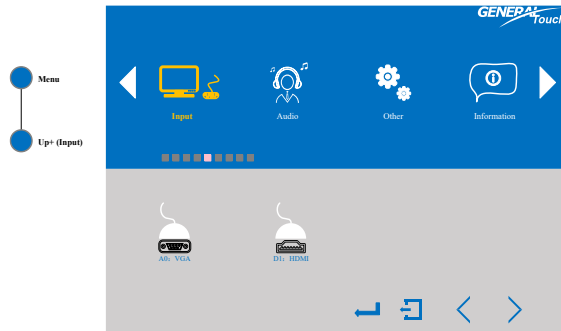

After pressing the menu button (MENU) mentioned above, the OSD menu will open. In this menu, you can use the buttons on the back, such as (UP+) or (DOWN-), to navigate horizontally. Press the menu button (MENU) again to select the highlighted menu item and enter the "Input" menu.

The "Input" menu provides the following setting options: A0: VGA (analog signal), D1:HDMI (digital signal).

6.2.4.6 Audio

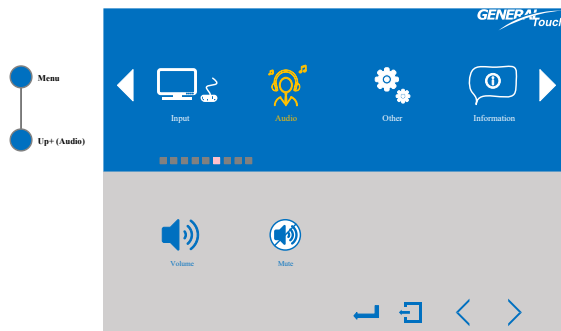

After pressing the menu button (MENU) mentioned above, the OSD menu will open. In this menu, you can use the buttons on the back, such as (UP+) or (DOWN-), to navigate horizontally. Press the menu button (MENU) again to select the highlighted menu item and enter the "Audio" menu.

The "Audio" menu provides the following setting options: Volume, Mute.

The adjustment range for Volume: 0~100

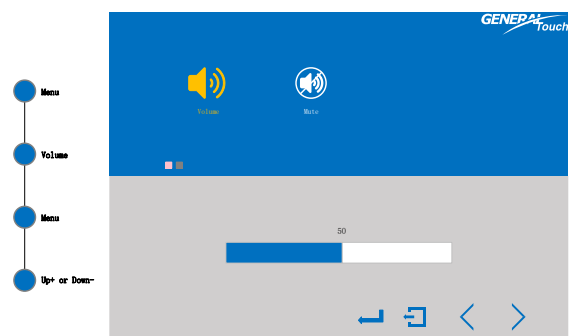
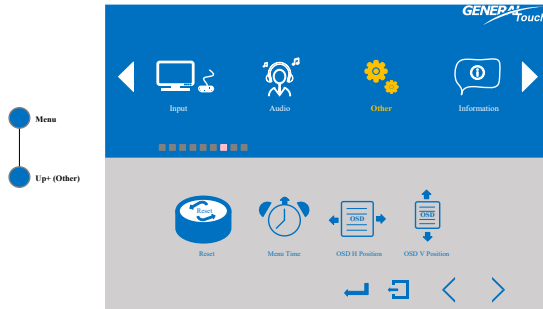

Fig 69 Volume in the "Audio" Menu

6.2.4.7 Other



After pressing the menu button (MENU) mentioned above, the OSD menu will open. In this menu, you can use the buttons on the back, such as (UP+) or (DOWN-), to navigate horizontally. Press the menu button (MENU) again to select the highlighted menu item and enter the "Other" menu.

The "Other" menu provides the following setting options: Reset, Menu Time, OSD H Position, OSD V Position, Language, Transparency, Rotate.

<p>Reset state</p>	<p>Fig 70 Reset in the "Other" Menu</p>
<p>The adjustment range for Menu Time: 0~100</p>	<p>Fig 71 Menu Time in the "Other" Menu</p>

The adjustment range for OSD H Position: 0~100

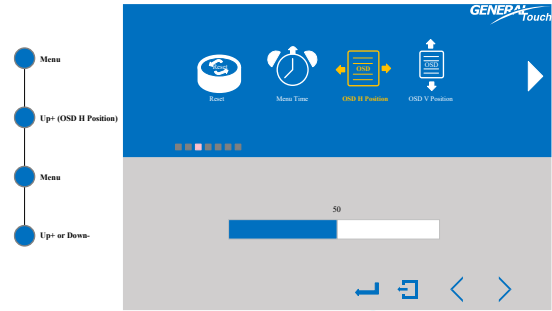

Fig 72 OSD H Position in the "Other" Menu

The adjustment range for OSD V Position: 0~100



Fig 73 OSD V Position in the "Other" Menu

Language optional; English, Français, Deutsch, Español, Italiano、简体中文

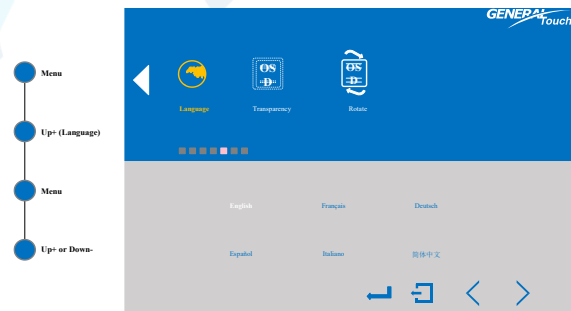

Fig 74 Language in the "Other" Menu

The adjustment range Transparency: 0~100

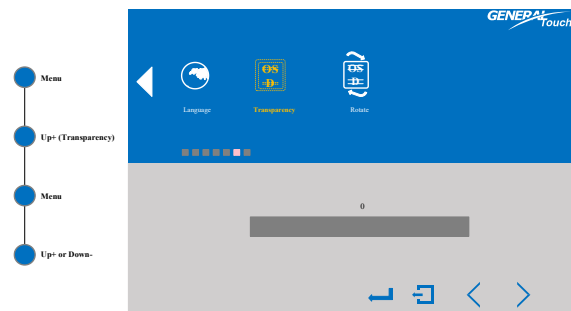

Fig 75 Transparency in the "Other" Menu

Rotate optional: 0, 90, 270, 180

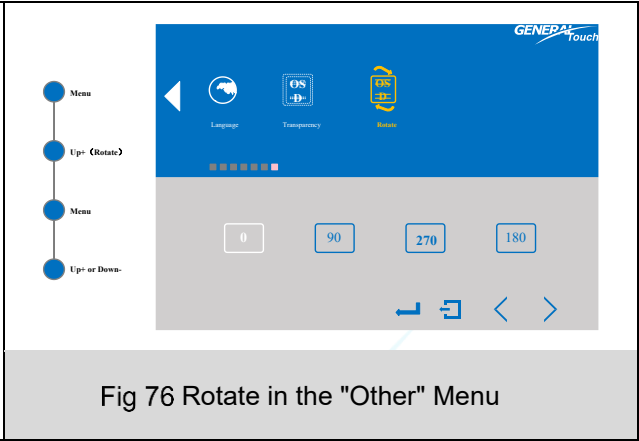
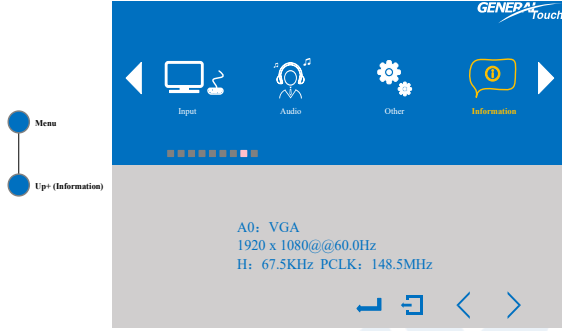

Fig 76 Rotate in the "Other" Menu

6.2.4.8 Information



After pressing the menu button (MENU) mentioned above, the OSD menu will open. In this menu, you can use the buttons on the back, such as (UP+) or (DOWN-), to navigate horizontally. Press the menu button (MENU) again to select the highlighted menu item and enter the "Information" menu.

The "Information" menu allows you to view the following information: signal sources (VGA or HDMI), resolution, refresh rate etc.

TROUBLESHOOTING GUIDE

This section provides an overview of common types of product malfunctions and troubleshooting methods.

7 TROUBLESHOOTING GUIDE

7.1 Types of Malfunctions

For our touch display monitors, the common types of malfunctions can be categorized into touch-related issues and display-related issues.

7.2 Troubleshooting Process

If you encounter any abnormalities while using our touch display monitor, please first determine the type of malfunction, and then refer to the "Common Malfunction Reference Table" for preliminary analysis and assessment. If you are unable to troubleshoot the issue and restore normal operation, please follow our After-sales Process to request assistance.

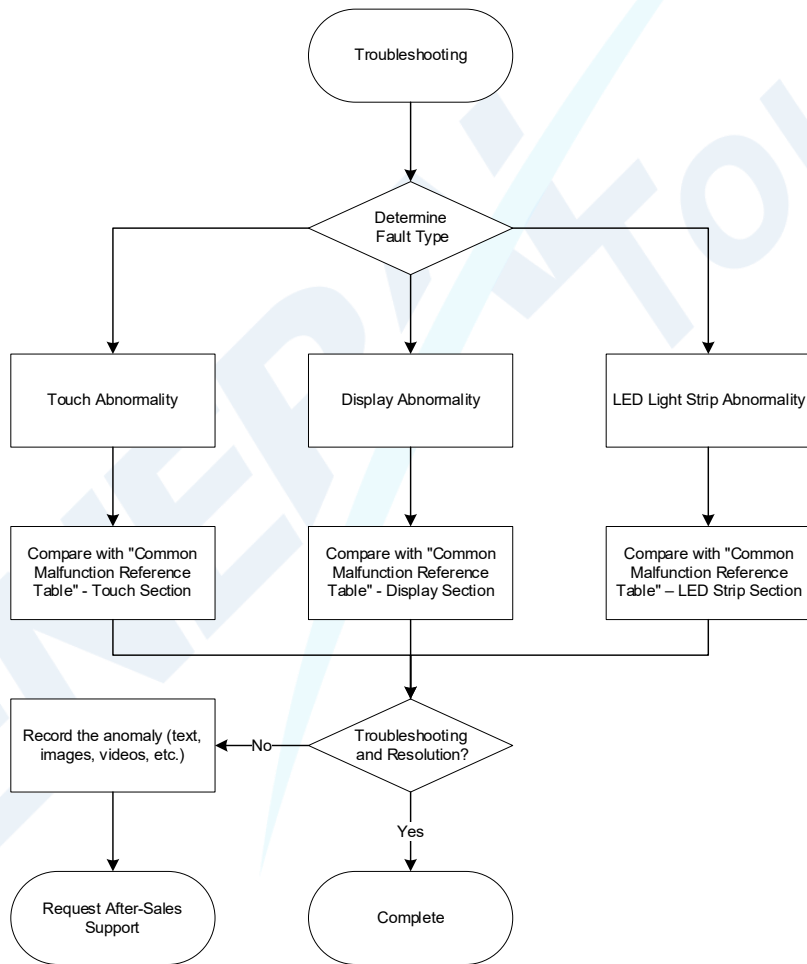

Fig 77 Common Troubleshooting Process

7.3 Common Malfunction Reference Table

If you encounter any malfunctions or abnormalities while using the touch display monitor, please refer to the following suggestions. If the issue persists, please contact your local dealer or reach out to General Touch’s after-sales support.

Table 6 Common Malfunction Reference Table

Fault Code	Fault Category	Common Issues	Possible Causes	Troubleshooting Methods	Fault Severity
TP-1		Erratic touch input	Program configuration error	Reconfigure parameters	I
TP-2			External environmental interference	Measure static sensitivity through signal testing	
TP-3			Controller damage	Measure voltage or perform information testing	
TP-4	Capacitive Touch	Broken lines at the edges or incomplete lines	Resolution mismatch	Specifically for some irregular screens, specialized resolutions need to be matched	II
TP-5			Resolution mismatch	Observe edge signal values through signal testing	
TP-6			Damaged channels edge	Visual observation or continuity testing Continuity testing	
TP-7			Damaged FPC ribbon cable or sensor	Continuity testing	
TP-8		Touch lock points	Abnormal screen panel	Perform signal testing and observe if the screen panel meets flatness standards	II
TP-9			Electromagnetic interference	Observe CDC static changes	
TP-10			Controller malfunction	Perform cross-testing by replacing the screen panel	

Fault Code	Fault Category	Common Issues	Possible Causes	Troubleshooting Methods	Fault Severity
TP-11				Test CDC static changes of the controller	
TP-12		Unresponsive touch (delayed or broken lines when drawing)	Decreased signal sensitivity	Read information values using information testing tools	II
TP-13	Outdated motherboard driver version		Reload driver software, mainly for Android or Linux		
TP-14	Abnormal firmware parameter		Reconfigure firmware parameters		
TP-15	Using fingertips instead of finger pad during touch testing		Perform touch testing using finger pad		
TP-16		Touch non-responsive	Touch display not connected to the host	Check if the host is connected or use the system "Device Manager" to see if devices are connected, and reconnect and reinsert signal cables	II
TP-17	Damaged signal cable		Replace signal cable (Type-B to Type-A)		
TP-18	Poor contact between touch screen and controller		Disassemble and reinsert FPC ribbon cables		
TP-19	Incorrect firmware or program writing		Reflash firmware		
TP-10	Other issues		Read screen panel signal waveform		

Fault Code	Fault Category	Common Issues	Possible Causes	Troubleshooting Methods	Fault Severity
TP-21		Loose or disconnected screen wires	Abnormal sensor channels	Test channels through signal testing	II
TP-22			Damaged sensor	Visual observation	
TP-23			Damaged FPC ribbon cable	Visual observation	
TP-24			Incorrect firmware parameter configuration	Update firmware	
D-1	Display	Black screen	Power not connected	Check if the power is properly connected and check the indicator light status for indicator light	II
D-2			Video cable not connected	Connect and reconnect	
D-3			Other issues	Contact us	
D-4		Inverted display image	Incorrect OSD settings	Adjust in the OSD menu.	I
D-5		Screen distortion	Loose video cable	Connect and reconnect	II
D-6		Other issues	Any other display-related abnormalities	Contact us	II
L-1	LED strips	The LED strips don't work.	There is a discrepancy between the output voltage and power of the power supply and the operating voltage and power of the LED Strip.	It is recommended that the adapter be replaced and that the device be rebooted.	I

Fault Code	Fault Category	Common Issues	Possible Causes	Troubleshooting Methods	Fault Severity	
L-2			The LED Strip is damaged.	The LED Strip is to be replaced.	II	
L-3			The LED Strip connector interface is damaged.	The LED Strip connector interface is to be replaced.	II	
L-4			In the event that the internal power supply scheme is not functioning correctly, it is possible that the connecting wires may have poor contact.	The connection cable must be replugged.	II	
L-5			In the event of an external power supply scheme, a potential discrepancy may exist between the LED Strip controller and the light bar.	The LED Controller is to be replaced.	I	
L-6			Some of the LEDs of the LED Strip exhibited a lack of brightness or were dim.	A discrepancy exists between the number of LEDs set by the software and the actual number of LEDs present in the LED Strip.	It is necessary to reset the number of LEDs on the software.	I
L-7				A reduction in voltage or loss of signal may be the cause.	It is necessary to select the appropriate power adapter and connection cable.	I
L-8				The LED is damaged.	The LED Strip is to be replaced.	II

Fault Code	Fault Category	Common Issues	Possible Causes	Troubleshooting Methods	Fault Severity
L-9		The LED Strip is observed to be flashing.	An anomalous power supply	It is necessary to select the appropriate power adapter.	I
L-10			The LED controller's protocol is not aligned with the specifications of the LED protocol.	It is recommended that a LED controller be selected that is compatible with the LED protocol.	I
L-11			The LED is damaged.	The LED Strip is to be replaced.	II
L-12		Inconsistency in the color of LEDs	The LED controller's protocol is not aligned with the specifications of the LED protocol.	It is recommended that a LED controller be selected that is compatible with the LED protocol.	I
L-13			An error has occurred in the setting of the LED color.	It is imperative that the LEDs are set to the same color as the other LEDs.	I
L-14			The LED is damaged.	The LED Strip is to be replaced.	II

SERVICE AND SUPPORT

This chapter mainly introduces our after-sales service and technical support.

GENERATOR TOUCH

8 SERVICE AND SUPPORT

8.1 Pre-sales Consultation

We provide professional pre-sales consultation services to our users. You can obtain timely and comprehensive information about our products and corresponding services through various channels such as our official website, email, and telephone.

8.2 After-sales Service

If you have any questions about the product or need assistance with equipment malfunctions, you can first refer to the user manual and frequently asked questions available on our website. If the issue persists, please contact us directly.

To provide global support, we collaborate with local representatives/service providers to assist customers with support and services. For more information, you can contact us or leave a message using the following methods, and we will respond promptly and provide assistance as soon as possible!

8.2.1 After-sales Process

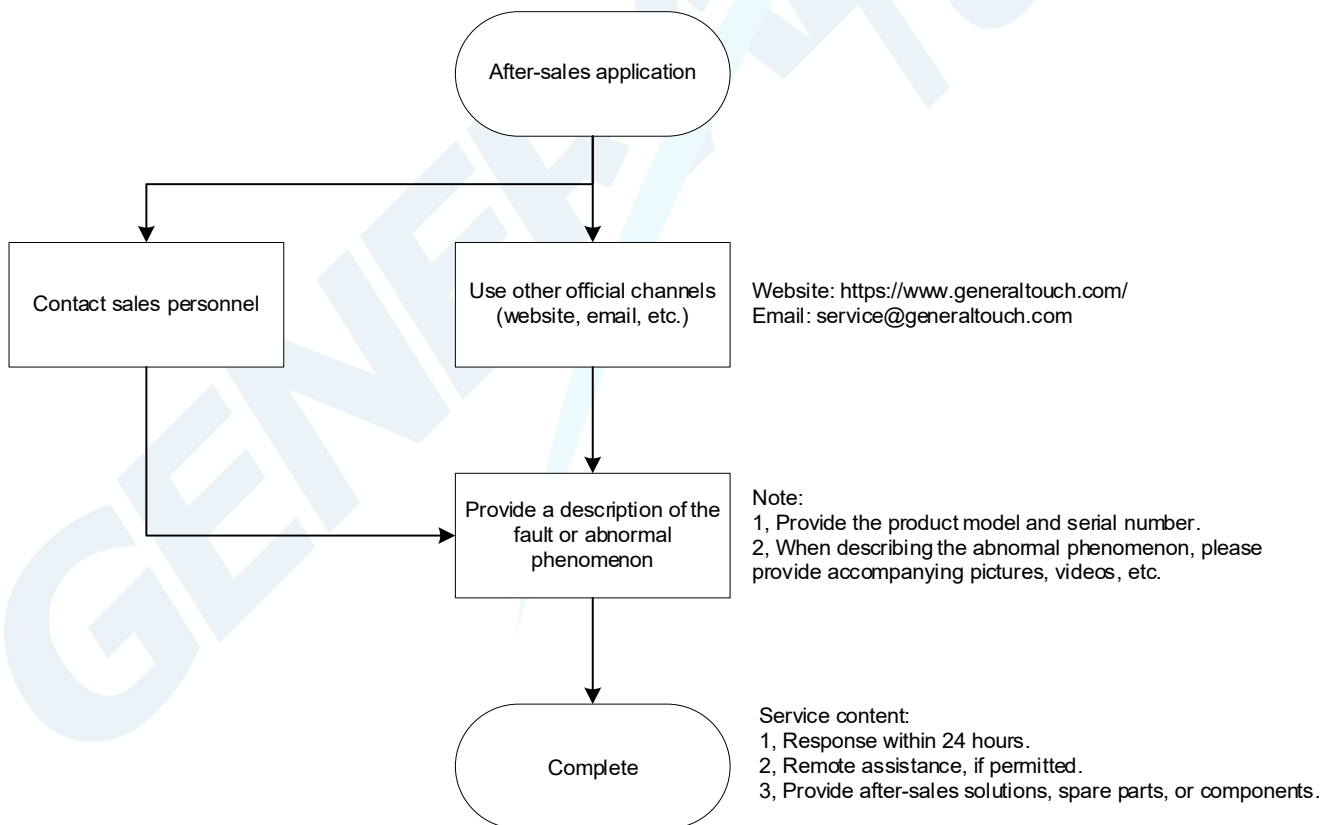

Fig 78 After-sales Process

8.2.2 Warranty Policy

The following is our product warranty commitment. During the warranty period, we provide free product repairs and replacement services for key components. For products that have exceeded the warranty period, we may charge a certain fee. For more details, please refer to our warranty policy on the official website under the "[Warranty Services](#)" section. Throughout the entire lifecycle of the product, you can expect comprehensive service from our company. The warranty policy provided below is for reference only. In case of any inconsistencies, the contract or specification sheet shall prevail.

Table 7 Warranty Policy

Touchscreen Components	SAW		5 Years
	PCAP		3 Years
	IR		1.5 Years
	FOG/Touch film/Touch Glass		6 months
	Resistive		1 Year
Touch Monitor	Flat	Not High TNI & High Brightness	3 Years
		High TNI & High Brightness	1 Year
	Curved		1 Year
Touch Computer (All-In-One)	With or without touch function		2 Years
Touch & Display Kits	Touchscreen and LCD panel bonded together		1 Year

8.2.3 Service Assurance

We are based in Chengdu, China, and have established after-sales repair centers in Europe. We also work with local agents and partners in the Americas, India, and other regions to provide diverse after-sales services.

We have dedicated departments and professionals to promptly and efficiently respond to customer needs. For common issues, we provide online consultation and support. For severe faults that require factory repairs, we offer return-to-factory repairs and the option of sending spare parts, based on our warranty policy.

8.3 Customization Services

We specialize in providing professional customized solutions for users. Based on your needs, we can offer complete product customization, such as touchscreens, touch displays, and all-in-one touch systems. You can learn about our customization service policies and options on the official website under "[Customer Customization](#)", or you can directly consult with us.

8.4 Debugging and Firmware Upgrades

Our closed frame touch displays usually do not require additional debugging and can be used directly. However, if you have specific requirements for touch experience, we also provide corresponding services, including touch calibration, touch signal testing, and firmware upgrades.

8.4.1 Debugging

8.4.1.1 Touch Calibration

Our touch displays are calibrated before leaving the factory and do not require manual calibration. However, for specific user requirements, we can provide calibration tools for you to choose from during the use of our products to adapt to different usage scenarios.

8.4.1.2 Touch Signal Testing

This is mainly provided when needed for maintenance or troubleshooting purposes, to assist you in identifying the source of faults.

8.4.2 Firmware Upgrades

For touch displays, our firmware includes touch-related firmware and display-related firmware. They are already adapted and debugged during the production process and do not require separate or additional firmware writing.

Our products support firmware upgrades for both functional improvements and fault troubleshooting. You can obtain firmware through official channels and use our dedicated tools. Please note that we reserve the right to refuse after-sales support for any damage or faults caused by the use of unofficial firmware provided by other companies.

8.4.2.1 Touch Firmware

Touch firmware upgrades can be directly written using software and can adjust touch sensitivity, sensing levels, etc.

8.4.2.2 Display Firmware

Display firmware needs to be written using separate tools and can preset features such as startup screen logo and display ratios.

APPENDIX

This chapter primarily introduces the product models within this series, as well as some terms and annotations.

9 APPENDIX

9.1 Specifications

9.1.1 Dimensions

For detailed dimensions and specifications, please refer to the sales drawings.

9.1.2 Technical Indicators

9.1.2.1 Display Parameters

For detailed specifications, please refer to the specification sheet.

9.1.2.2 Touch Performance

For conventional capacitive touch displays, they support up to 10-point touch with touch gestures including tapping and multi-point drawing. For acoustic touch displays, they support single-point touch with touch gestures including tapping and single-point drawing.

9.1.3 Environmental Adaptability

The general working environment for conventional models is as follows:

Operating temperature: 0 ~ 40°C.

Storage temperature: -20 ~ 60°C.

Operating humidity: 20% ~ 80%.

Storage humidity: 10% ~ 90%.

The above working environment requirements are based on common and general usage scenarios for conventional models. We can also provide special design improvements to meet stricter environmental requirements for specific working environments.

9.2 Terms

OSD: On-Screen Display

PCAP: Projected Capacitive Touch

VESA: Video Electronics Standards Association

LED: Light-Emitting Diode

RGB: Red Green Blue

PCB: Printed Circuit Board

9.3 Contact Us

Address: No. 6, Keyuan South Road, Chengdu High-tech Zone, Sichuan Province, China

This manual may be subject to updates without prior notice.

You can check the latest version on the General Touch official website or contact us directly.

<https://www.generaltouch.com/>

If you have any questions or suggestions regarding the user manual, please contact us via the following email: info@generaltouch.com.

General Touch is a registered trademark of General Touch Co., Ltd.

Copyright © 2026 General Touch. All rights reserved.