

Panel Mount Touch Monitor

USER MANUAL



Please read this manual carefully and keep it
in a safe place before use.

V1.5 2026.06





This manual is copyrighted and owned by General Touch Co., Ltd. (referred to as "General Touch"). Without written authorization from General Touch, any individual or entity is prohibited from copying, scanning, storing, disseminating, reprinting, selling, transferring, or modifying the entire or partial content of this manual in any way, whether for personal or third-party use. This manual and its content are solely intended for the operation and use of the panel mount touch display series products and should not be used for any other purposes.

The images in this manual (including but not limited to their models, appearance, colors, dimensions, screen display content, etc.) are for illustrative purposes only. Please refer to the actual product for accuracy.

READING TIPS

Symbol Key

	Note or Information		Warning		Caution
---	---------------------	---	---------	---	---------

USAGE RECOMMENDATIONS

General Touch provides you with the following documentation:

"Sales Drawing"

"Specification Sheet"

"User Manual"

We recommend starting with the "Specification Sheet" to learn about the touch display's specifications and structural dimensions. For more information, refer to the "Sales Drawing". To fully understand the product, please read the "User Manual."

The introductory page of each chapter in the user manual provides an overview of the chapter's content.

This manual is intended for panel mount touch monitor.

CATALOGUE

Reading tips	2	3.4.3 Usage	18
1 Precautions Before Use.....	2	3.4.4 Cleaning, Maintenance, and Repair.....	23
1.1 Safety Precautions.....	2	4 Troubleshooting Guide	26
1.1.1 Safety Precautions for Using a DC Power Supply	3	4.1 Types of Malfunctions	26
1.2 Delivery Status.....	4	4.2 Troubleshooting Process	26
1.3 Delivery Checklist	4	4.3 Common Malfunction Reference Table.....	27
1.4 Preparation	5	5 Service and Support	31
1.5 FCC Statement.....	6	5.1 Pre-sales Consultation.....	31
2 Overview	8	5.2 After-sales Service.....	31
2.1 Product Definition	8	5.2.1 After-sales Process.....	31
2.2 Key Features	8	5.2.2 Warranty Policy.....	32
2.3 Application Scenarios	8	5.2.3 Service Assurance	32
3 Product Description.....	10	5.3 Customization Services	32
3.1 Exterior	10	5.4 Debugging and Firmware Upgrades	33
3.2 Components Introduction.....	11	5.4.1 Debugging	33
3.2.1 Structure	11	5.4.2 Firmware Upgrades	33
3.2.2 Interfaces	13	6 Appendix.....	35
3.2.3 Power Supply.....	15	6.1 Specifications.....	35
3.2.4 Craftsmanship.....	15	6.1.1 Dimensions.....	35
3.3 Accessories	15	6.1.2 Technical Indicators.....	35
3.4 Operation Instructions.....	16	6.1.3 Environmental Adaptability	35
3.4.1 Unboxing	16	6.2 Terms.....	35
3.4.2 Installation	16	6.3 Contact Us	35

PRECAUTIONS BEFORE USE

This section primarily covers some important points to note when using the product.

GENERATOR TOUCH

1 PRECAUTIONS BEFORE USE

1.1 Safety Precautions



Here are some safety precautions to be followed when using our product. Please read and adhere to them carefully.

Before cleaning the product, make sure to unplug the power cord, and wipe the product with a soft, dry cloth.

Do not use components other than those recommended by the manufacturer, as it may cause damage.

Do not attempt to drag the monitor by its power cord, and do not touch the plug with wet hands.

Avoid excessive bending of the plug and power cord, and do not place heavy objects on them to prevent damage.

Place the product in an area away from oil, smoke, or moisture to avoid malfunction, electric shock, or fire. Particularly, avoid operating the monitor near water or outdoors where it may be exposed to rain or snow.

Do not block the ventilation openings on the monitor casing, and do not place the monitor or power adaptor on a bed, sofa, carpet, etc., as poor ventilation may cause malfunctions or fire.

When installing the product, ensure that it is positioned at least 76 mm away from the wall for proper ventilation.

Use only the power source type listed on the product label. If you have any doubts about the power source, please contact local dealer or power supply department.

Use only properly grounded plugs and outlets, as improper grounding may result in electric shock or device damage. If plug cannot be inserted into the outlet, please replace the outlet.

Ensure that the outlet can handle the total electrical load of the connected product. Do not connect too many extension cords or plugs to a single outlet, as it may cause a fire.

Do not place the product on an unstable or narrow surface. Place it on a flat and stable surface to prevent the product from falling and causing harm to passersby, especially children.

Do not attempt to extend the power cord, as it may cause a fire.

Do not disassemble the monitor case by yourself. If the monitor needs inspection or repair, please contact a professional service technician.

In case of the following situations, unplug the power cord first and then contact a professional service technician:

- ◆ The power cord is damaged or broken.
- ◆ The monitor fell and damaged the casing.
- ◆ The monitor display is not functioning correctly and needs to be repaired.

When not using the monitor, unplug the power cord from the power outlet.

Do not install the product in areas with poor ventilation, strong direct light, high temperature, or high humidity.

It is important to note that the corners of the tempered glass are relatively fragile. Therefore, it is essential to exercise caution and protect the four corners of the touch screen throughout the entire process of installation and use. This is to prevent any potential damage from contact with sharp objects or from impact.

1.1.1 Safety Precautions for Using a DC Power Supply

To ensure safe equipment operation, please comply with the following regulations when using a DC power supply.



Mandatory Protection Measures:

The DC power supply used must be equipped with an overcurrent protection circuit (OCP). It is strictly forbidden to connect any bare power supply without overcurrent protection functionality (such as simple batteries, transformers, or switching power supplies that are unregulated or lack a protection circuit).

For the best user experience and device stability, we recommend using our original factory adapter. If you need to use a third-party DC power supply, please refer to the parameters in the table below for selection and ensure that the power supply is equipped with overcurrent protection (OCP). Choosing the right power supply contributes to long-term stable operation of the device.

Rated Voltage	Typical Power Consumption	Rated Current	Recommended Supply-side Threshold Current
12V	50W	4.17A	5.0A
	60W	5.0A	5.8A
	90W	7.5A	9.0A
24V	150W	6.25A	7.5A

Note: For DC power supply specifications applicable to different monitor models, please refer to the detailed adapter descriptions in the "Optional Accessories" section of the specification sheet.

1.2 Delivery Status

According to the product specifications, all components are delivered with specific hardware or software configurations, including firmware versions. It is important to note that any modifications or changes made to the hardware or software configurations (including firmware versions) beyond the specified limits are not allowed for this product. In such cases, General Touch (the company) will not be held responsible for any consequences or liabilities that may arise.

1.3 Delivery Checklist

Number	Name	Quantity	Remarks
1	Touch monitor	1	
2	Power cable	1	
3	Power adaptor	1	
4	USB cable (Type-B to Type-A)	1	For Touch Monitor
5	Clamps	8	Accessories for installation
6	Video Cable	1	VGA, HDMI, etc.
7	Specification sheet	1	Electronic version
8	Sales drawing	1	Electronic version
9	User manual	1	Electronic version

1.4 Preparation

This manual is designed for panel mount touch monitors and covers basic information such as product introduction, installation and usage instructions, troubleshooting, and more.

For our touch monitor, it is important that the operators have a certain level of professional knowledge and experience.

Here are some essential elements to ensure the proper functioning of the touch monitor:



The power supply that matches the specifications of the touch monitor.

Before preparing to use the touch monitor, please make sure to determine the power supply that matches its specifications.

When installing and disassembling, it is necessary to turn off the power and then power on the monitor after assembly or installation is complete.



The touch monitor is compatible with certain operating systems for the host computer and supports specific video sources. It is important to use a compatible operating system for the host computer when using the touch monitor to ensure the touch functionality works properly. Using an incompatible operating system may result in the touch function not working or performing poorly.

Additionally, it is recommended to use a video source that has a resolution that is consistent with or supported by the touch monitor. Using a video source with an incompatible resolution may result in the inability to display content or poor display quality.

1.5 FCC Statement

Caution:

Changes or modifications not expressly approved by the party responsible for compliance could void the user's authority to operate the equipment.

Note: This equipment has been tested and found to comply with the limits for a Class B digital device, pursuant to part 15 of the FCC Rules. These limits are designed to provide reasonable protection against harmful interference in a residential installation. This equipment generates, uses and can radiate radio frequency energy and, if not installed and used in accordance with the instructions, may cause harmful interference to radio communications. However, there is no guarantee that interference will not occur in a particular installation. If this equipment does cause harmful interference to radio or television reception, which can be determined by turning the equipment off and on, the user is encouraged to try to correct the interference by one or more of the following measures:

- ◆ Reorient or relocate the receiving antenna.
- ◆ Increase the separation between the equipment and receiver.
- ◆ Connect the equipment into an outlet on a circuit different from that to which the receiver is connected.
- ◆ Consult the dealer or an experienced radio/TV technician for help.

OVERVIEW

This section primarily focuses on introducing the features and applicable scenarios of this product series.

GENERATOR TOUCH

2 OVERVIEW

2.1 Product Definition

The panel mount series models are designed as touch-enabled monitors specifically for industrial site environments. They support embedded mounting¹.

2.2 Key Features

PTL*** is a thin and light industrial touch display with low power consumption, ultra-thin body design, high-resolution display, and excellent multi-touch interaction experience. The structure is simple and reliable, the embedded installation is convenient, and the sealing performance is good. The front panel complies with IP65² protection level, and the front frame adopts black aluminum alloy brushing process to ensure reliability, durability and aesthetics.

2.3 Application Scenarios

Compared with ordinary consumer TVs or monitors, PTL***, with its industrial-grade high performance and professional design, is more suitable for human-computer interaction scenarios in industrial environments such as factories and production lines.



Industrial site environments

¹ Note on locking torque of clamps during installation: Set the torque driver to 8.0-8.2kgf/cm. Ensure that the clamps are placed vertically to prevent shifting during the locking process.

² Regarding the IP65 protection level claimed in the product specification: Our panel mount series touch monitors can achieve an IP65 protection level, but it requires proper installation to achieve this effect. The touch monitors and cabinet must be installed correctly according to the installation steps and requirements. The cabinet surface must be flat and without deformation after installation, and the clamps must be firmly attached to the back panel of the cabinet. Please refer to section [3.4.2.1](#) for specific installation instructions.

PRODUCT DESCRIPTION

This chapter primarily covers the components, installations, usage, and routine maintenance of the product.

GENERATOR TOUCH

3 PRODUCT DESCRIPTION

3.1 Exterior

The front of the touch monitor is covered by a high-strength tempered glass, which ensures the overall protection of the device without compromising its display quality and touch experience.



Front View of a Touch Monitor



The slanted side of the touch monitor is the bezel.

Slanted Rear Side of the Touch Monitor

There are two mounting holes on the side of the Touch Monitor. These holes are used to mount the clamps and secure the Touch Monitor to the cabinet.



Side of the Touch Monitor

3.2 Components Introduction

3.2.1 Structure

A touch monitor is generally composed of touch components, display module, and various structural components. The touch components mainly include the touch screen and touch controller as core devices. The display module contains the LCD panel, A/D board etc. The structural component primarily includes the front frame, metal plate, shielding cover, stand/base etc.

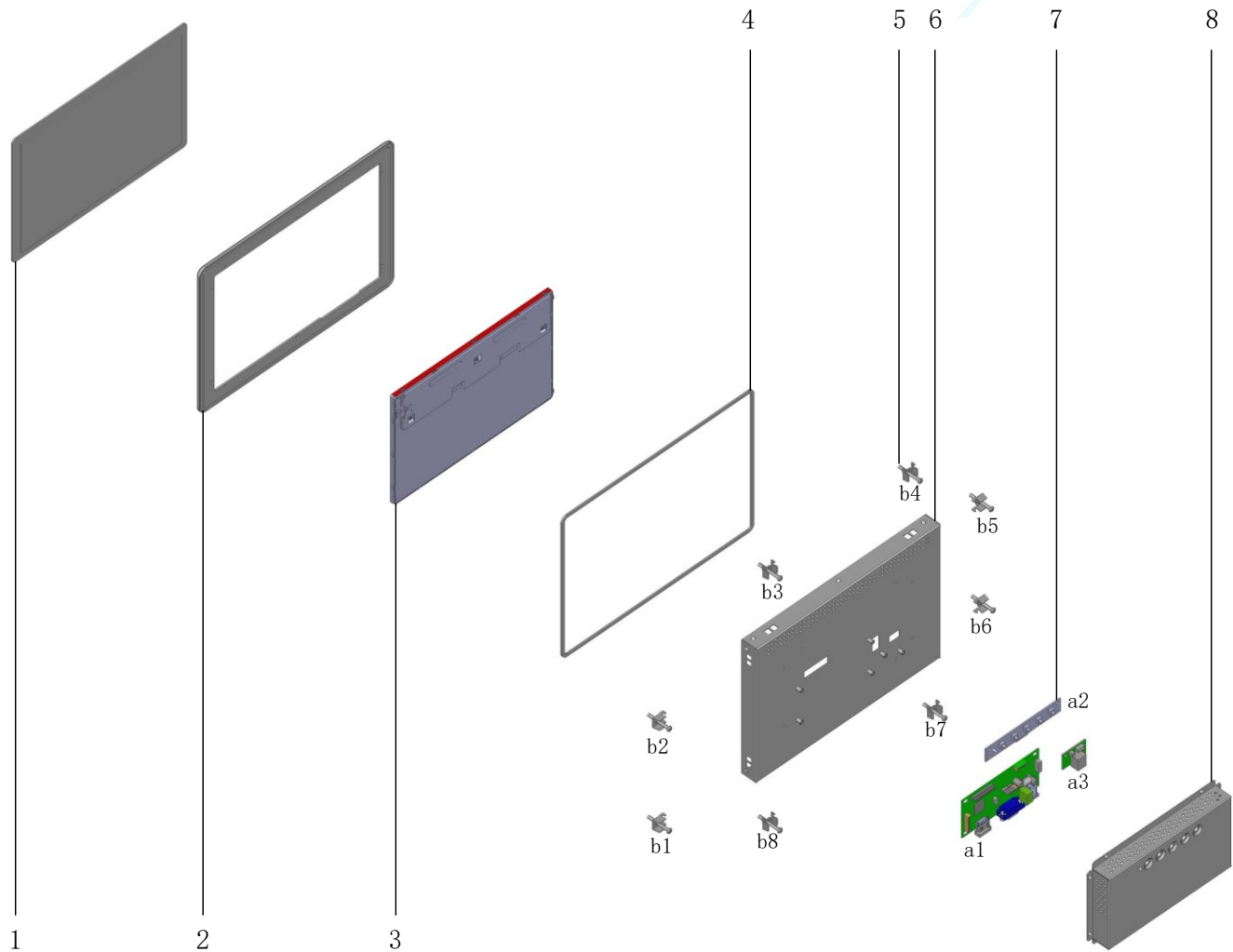

Fig 1 Cross-sectional view of the main structural components of a panel mount touch monitor

Touch Monitor Component

1 Touch Screen (include cover glass)	5 Clamps
Used for touch interaction	Includes b1, b2, b3, b4, b5, b6, b7, and b8, accessories for installation.
2 Front Frame	6 Metal Plate
Provides fixation and connects the screen body to the back cover	Provides fixation, fastening, and space for electronic components.
3 Panel	7 Electronic Components
Display the visual content.	Mainly include A/D board (a1), wire board (a3), OSD button board (a2), and their corresponding connecting cables. The COB solution includes a touch controller, while the COF solution integrates its touch controller into the FPC.
4 Waterproof Rubber Strip	8 Shield Cover
Structural elements for waterproofing.	Protecting the electronic components from damage.

3.2.2 Interfaces

3.2.2.1 External Interfaces

We offer a combination of VGA+HDMI interface on our touchmonitors to meet your needs.

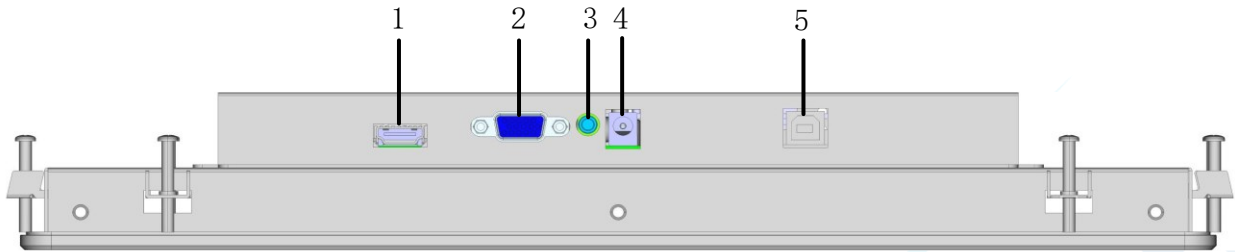

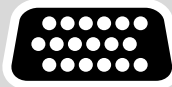



Fig 2 Bottom View of Touchmonitor

Touch Monitor's Interfaces Description

	<p>1 HDMI (High-Definition Multimedia Interface) Used for video signal</p>		<p>4 Power Supply DC input, DC plug 2.5mm</p>
	<p>2 VGA (Video Graphics Array) Used for video signal</p>		<p>5 USB Type B (Touch Port) Touch interface</p>
	<p>3 Audio-in Jack Microphone</p>		

3.2.2.2 OSD Button

The OSD (On-Screen Display) buttons are usually located on the back of the touch monitor to facilitate user operation.

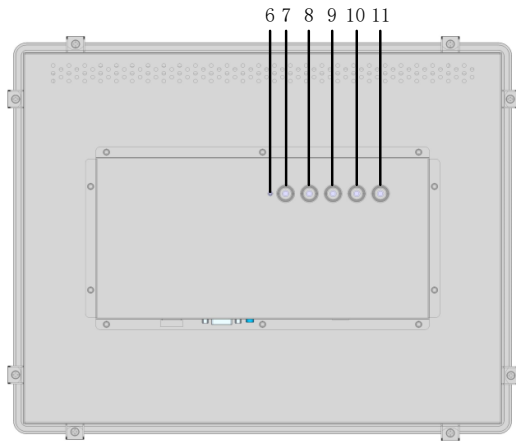

Back View of Touch Monitor

Touch Monitor OSD Button Description

- 7 Power
Power button, Turn ON/ OFF
- 8 Auto
Auto-adjust screen parameters, Exit/Return
- 9 Menu
Menu Button, confirm the selection
- 10 Up+
Adjustment button, Adjust Up/Right
- 11 Down-
Adjustment button, Adjust Down/Left

- 6 Indicator Light
Indicates the working status of the touch monitor



Off, not connected to power



Green, normal operation



Red, connected to power but in a non-working state

3.2.2.3 Clamps

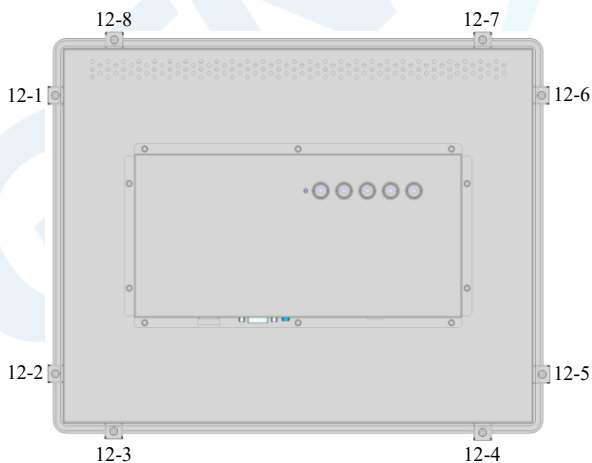

Illustration of Touch Monitor Clamps location

Clamps

For securing a touch monitor to a cabinet or backplane platform.

3.2.3 Power Supply

Typical power consumption for this model is less than 20 watts while utilizing a DC12V power supply.

3.2.4 Craftsmanship

For craftsmanship selection, we adhere to the principle of simple and refined design. We have developed a special process for the unique requirements of the industrial environments.

3.3 Accessories

We provide various types of accessories, such as HDMI cables, etc. The accessory images listed below are for display and illustration purposes only. Please refer to the actual product for accuracy.



Power Cable (Optional)



Power Adapter (Optional)



USB Cable (Type A to Type B)



VGA Cable (Optional)



HDMI Cable (Optional)

3.4 Operation Instructions

3.4.1 Unboxing

After taking our product out of the packaging box, first inspect the appearance, and then read the specifications and user manual one by one. Once confirmed, connect the touch monitor to the host and power it on. The steps to open the device packaging are as follows:

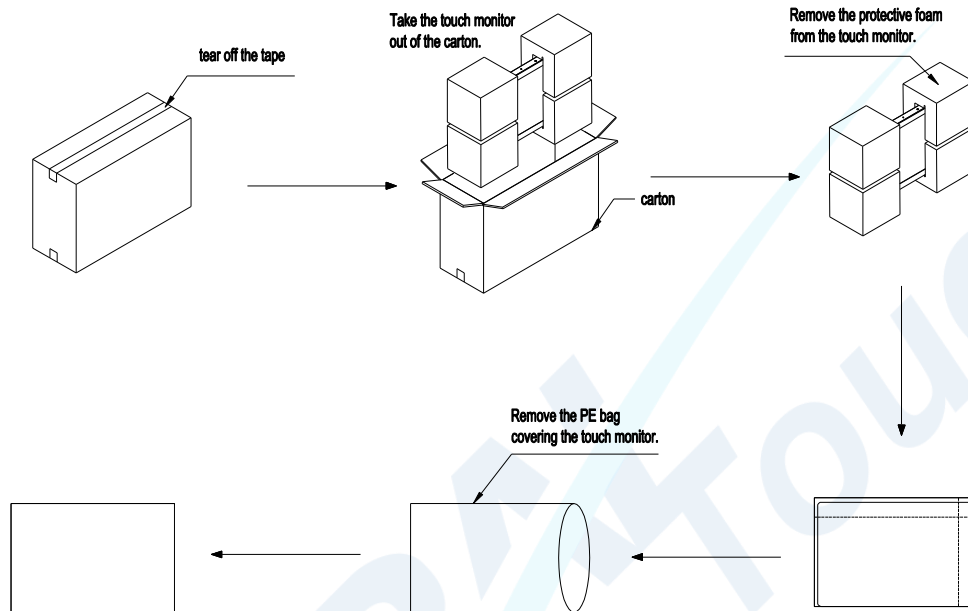

Fig 3 Standard Unboxing Process

Unboxing precautions:

- ◆ Do not discard the original packaging box.
- ◆ Check the goods list against your order to ensure completeness.
- ◆ Keep the documents that come with the device, as they contain important information about the device and how to use it.
- ◆ Check for any obvious transportation damage inside the packaging.

If you find any transportation damage or discrepancies between the packaging and the order, please inform General Touch's sales or after-sales department.

3.4.2 Installation

For our panel mount touch monitors, we utilize the mounting hole of the side of the Touch Monitor and clamps for embedded mounting.

3.4.2.1 Embedded Mounting

For embedded mounting, select an appropriate cabinet and secure it with clamps.

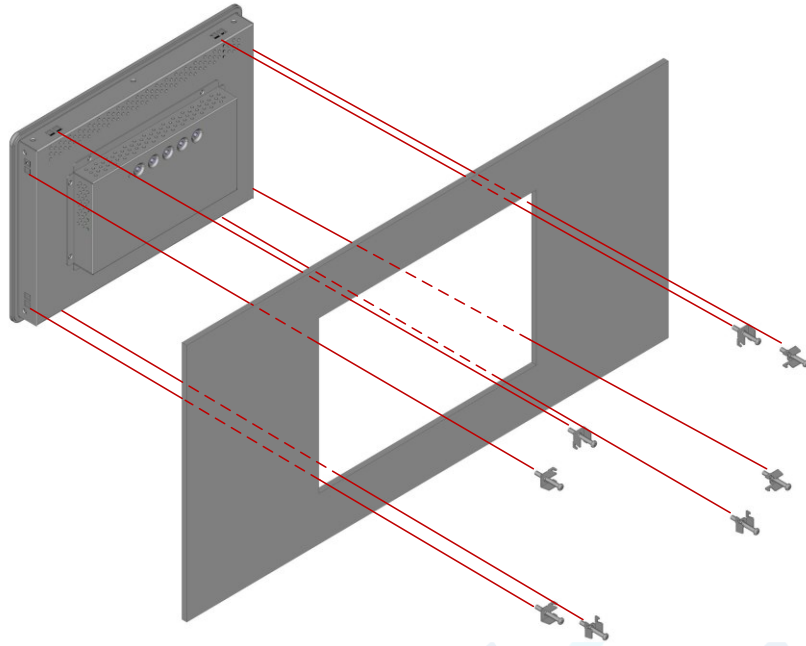
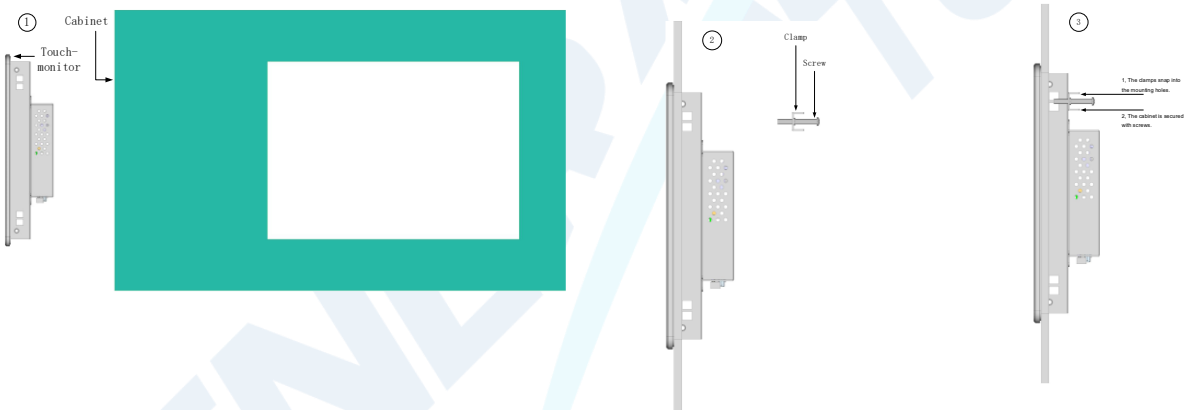

Fig 4 Embedded Mounting Installation Diagram

Here is a diagram of how the installation is broken down:



① Embed the touch-monitor inside the cabinet.

② Fit the touch-monitor to the cabinet. Remove the clips and screws.

③ The clamps snap into the mounting holes on the side of the touch-monitor. Tighten the screws until they are against the cabinet.

Diagram of the complete installation

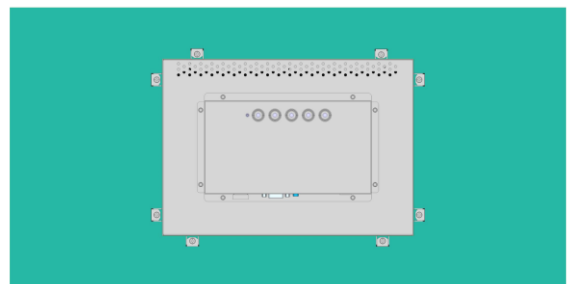

Front view of the touch-monitor

Back view of the touch-monitor

3.4.3 Usage

3.4.3.1 Connecting to the Host and Power

After installing the display, for the initial use, please connect the video cable first, then plug in the power and turn it on. During regular use, simply connect the power according to your habit.

The external interfaces are located at the back of the Touch Monitor, as detailed in section "3.2.2.1". To power on the device, use the provided power cable and adapter to connect it to the power source. Refer to the respective product label for all power-related information.

Once the power adapter is connected to the power source, the indicator light on the Touch Monitor will turn on and display red. After the host is powered on, the Touch Monitor will receive the video signal and display content, and the indicator light will turn green. The connection diagram is shown below:

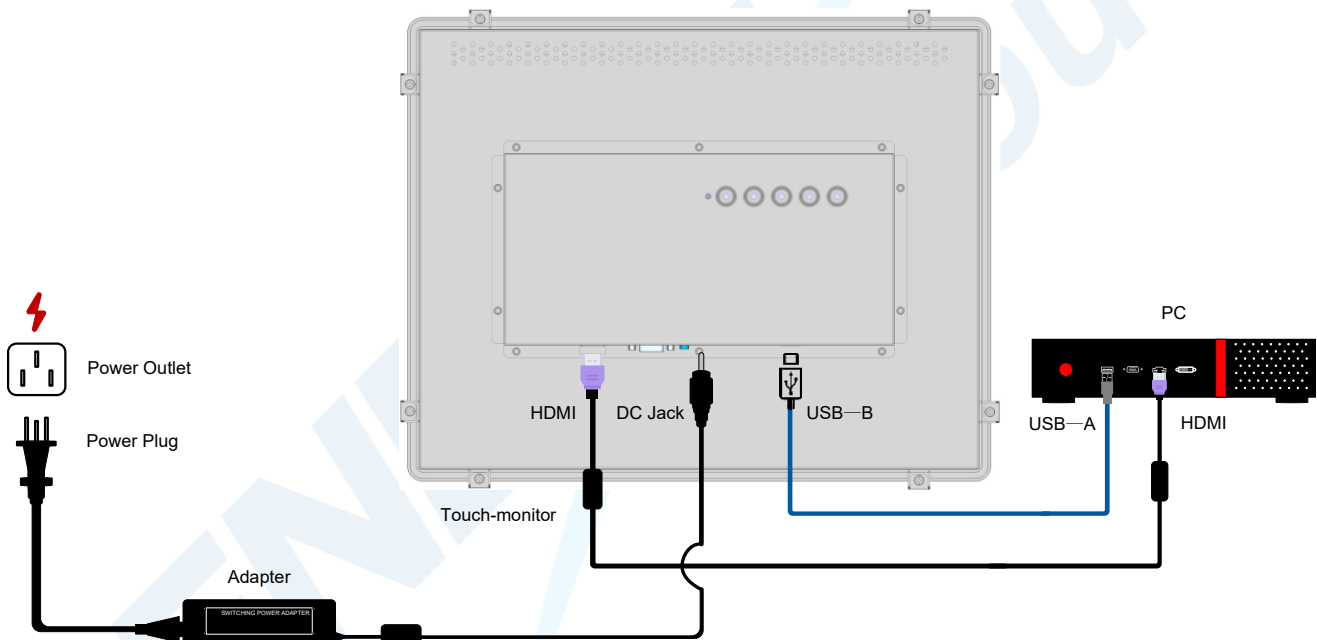





Fig 5 Touch Monitor Connection Diagram

Please note: In order to achieve optimal performance, it is generally recommended to match the computer's output resolution with the native resolution of the Touch Monitor for the best image quality. The product images shown in the connection diagram above are for illustrative purposes only. Please refer to the actual products for accurate representation. The host computer and power outlet are not provided by General Touch.

3.4.3.2 Touch

Our Touch Monitor supports various gesture operations such as tapping and swiping. Please refer to the following gesture table for more details:

Table 1 Touch Gesture Descriptions

Gestures	Name	Type	Descriptions
	Tap	Static Gestures	Single Finger (Pads) to Touch and Swipe the Screen
	Multi Tap	Gesture Operations	Multiple Fingers (Pads) to Touch and Swipe the Screen
	Swipe	Gesture Operations	Moving a finger (Pads) across the screen
	Other	Gesture Operations	Supports Touch Operations on Different Platforms

Note: The above gestures are based on the Windows Universal Platform for the host operating system, as well as support from certain applications. The icons are for reference only, and the actual display on the touchscreen may vary depending on the specific model.

3.4.3.3 OSD Settings

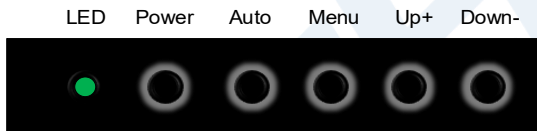

Fig 6 OSD Button Diagram

To adjust the screen and parameters of the Touch Monitor, it is necessary to understand the options and functions provided in the OSD menu (On-Screen Display), as well as how to use them. You can operate the OSD menu using the buttons located on the back of the Touch Monitor.

Note: It is important to familiarize yourself with the functions of each button, as described in section [3.2.2.2](#) regarding the explanation of OSD button functions, in order to successfully complete the OSD parameter settings. The following illustrations are for reference only. Different models may have slight differences in their display interface and operational methods (workflow), so please refer to the actual device for accurate information.

3.4.3.3.1 Colour Adjustment

After pressing the menu button (MENU), the OSD menu will open. In this menu, you can use the buttons on the back, such as (UP+) or (DOWN-), to navigate horizontally and vertically. Press the menu button (MENU) again to select the highlighted menu item and enter the "Colour" menu.

The "Colour" menu provides the following setting options: Contrast, Brightness, Colour Temp.

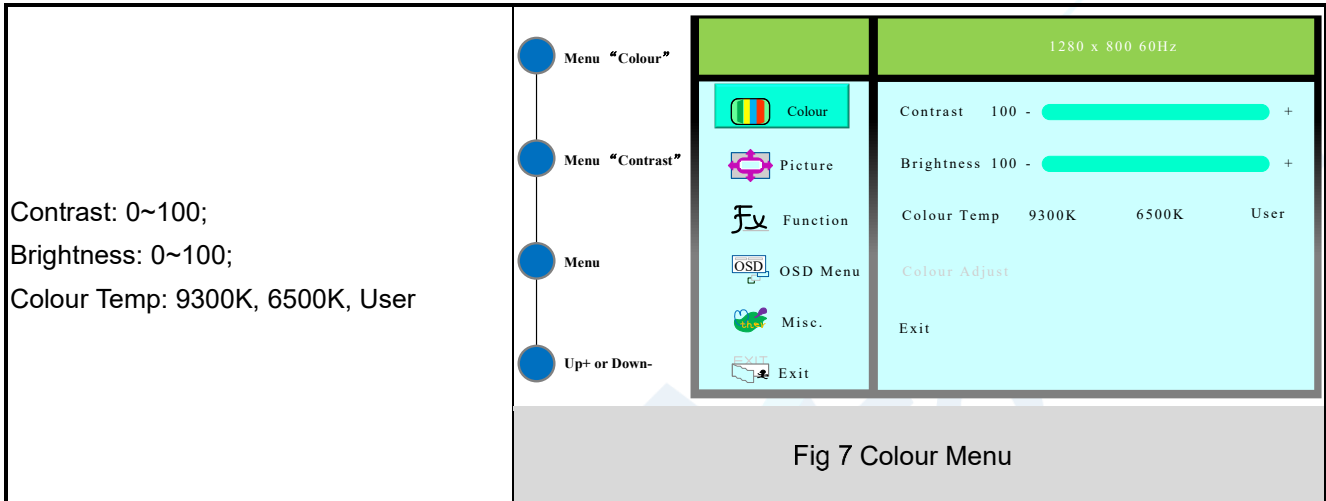

3.4.3.3.2 Picture Adjustment

After pressing the menu button (MENU), the OSD menu will open. In this menu, you can use the buttons on the back, such as (UP+) or (DOWN-), to navigate horizontally and vertically. Press the menu button (MENU) again to select the highlighted menu item and enter the "Picture" menu

The "Picture" menu provides the following setting options: H Position, V Position, Phase, Clock, Sharpness.

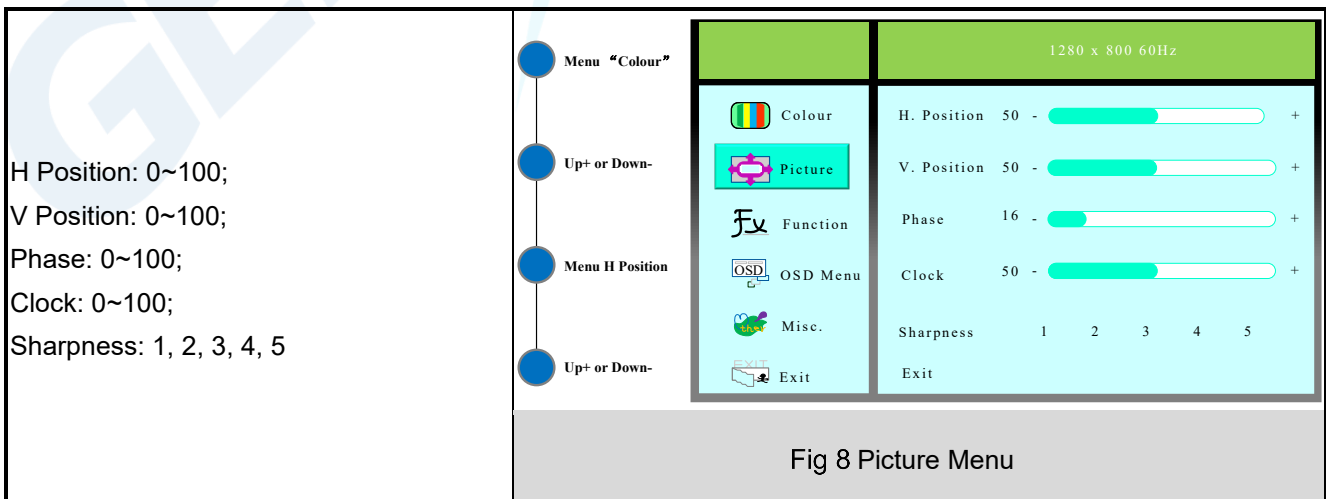

3.4.3.3.3 Function Adjustment

After pressing the menu button (MENU), the OSD menu will open. In this menu, you can use the buttons on the back, such as (UP+) or (DOWN-), to navigate horizontally and vertically. Press the menu button (MENU) again to select the highlighted menu item and enter the "Function" menu.

The "Function" menu provides the following setting options: Auto Adjust, Auto Colour.

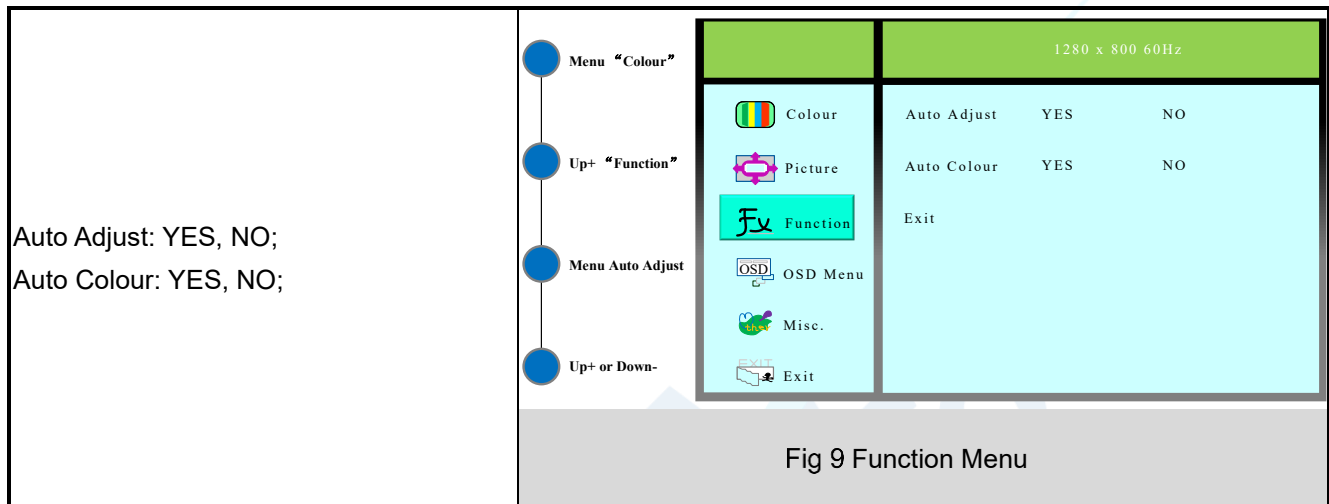

3.4.3.3.4 OSD Menu Adjustment

After pressing the menu button (MENU), the OSD menu will open. In this menu, you can use the buttons on the back, such as (UP+) or (DOWN-), to navigate horizontally and vertically. Press the menu button (MENU) again to select the highlighted menu item and enter the "OSD Menu" menu.

The "OSD Menu" menu provides the following setting options: Language, OSD H Position, OSD V Position, OSD Timer.

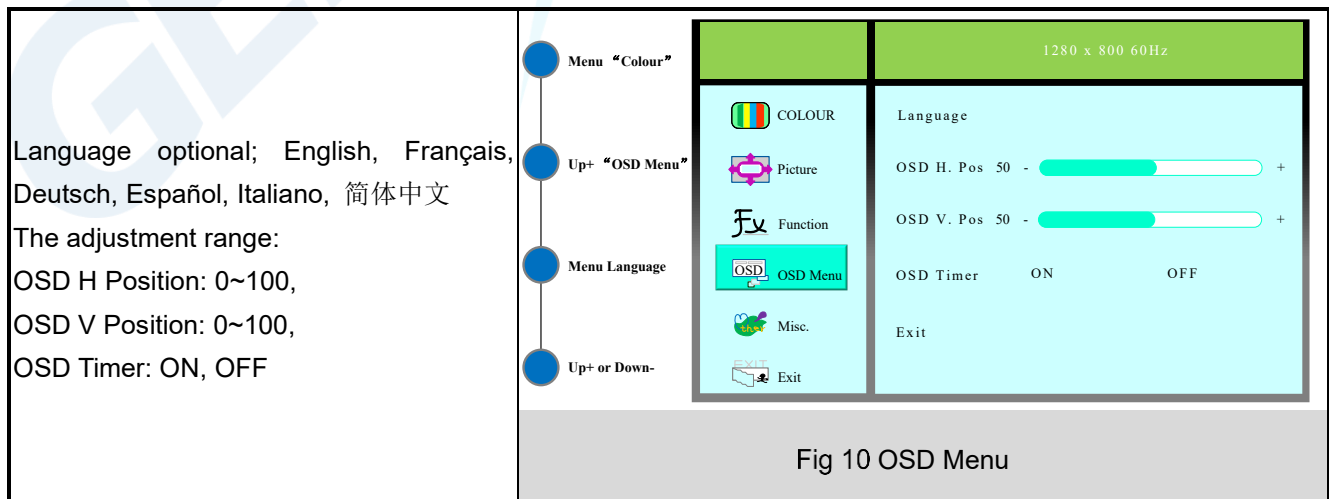

3.4.3.3.5 Misc. Adjustment

After pressing the menu button (MENU), the OSD menu will open. In this menu, you can use the buttons on the back, such as (UP+) or (DOWN-), to navigate horizontally and vertically. Press the menu button (MENU) again to select the highlighted menu item and enter the "Misc." menu.

The Misc. menu provides options for Input and Reset.

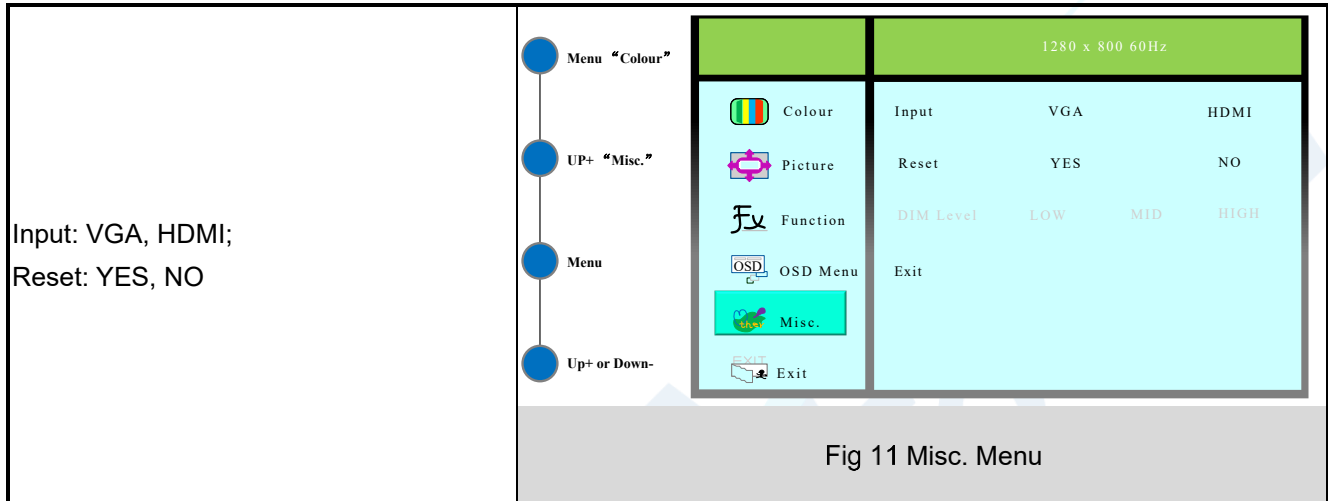

3.4.3.3.6 Exit Adjustment

After pressing the menu button (MENU), the OSD menu will open. In this menu, you can use the buttons on the back, such as (UP+) or (DOWN-), to navigate horizontally and vertically. Press the menu button (MENU) again to select the highlighted menu item and enter the "Exit" menu.

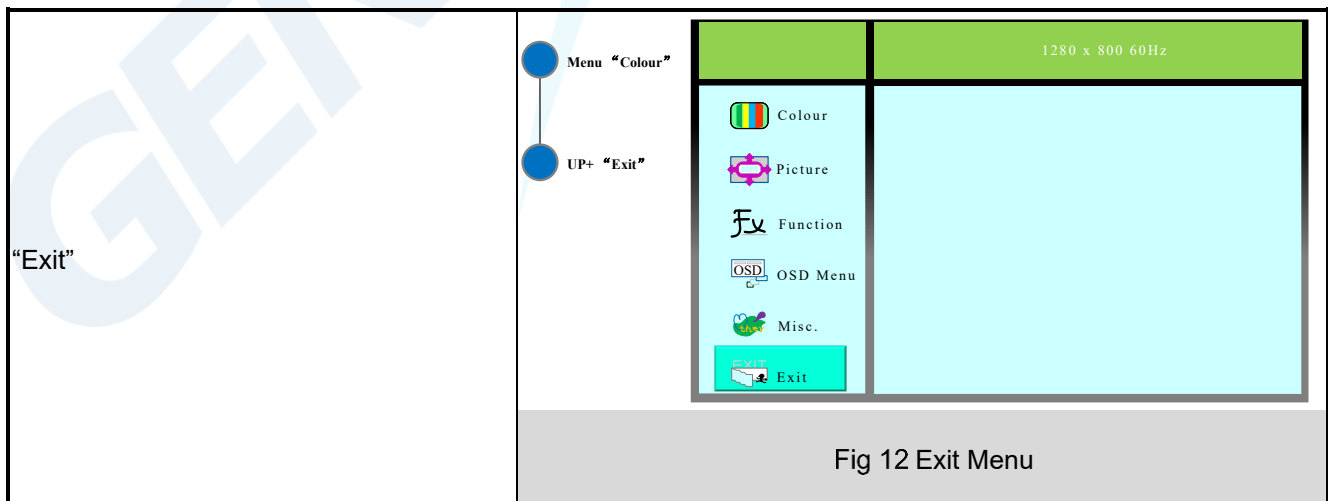

3.4.4 Cleaning, Maintenance, and Repair

3.4.4.1 Cleaning

Please keep the surface of the monitor clean to avoid affecting touch sensitivity. When cleaning the screen, gently wipe the surface with a specialized monitor cleaner and a soft cleaning cloth. Avoid using cleaners that contain alcohol, ammonia, or strong chemical ingredients as they may damage the screen.

Use a damp cloth with water to wipe the casing, without using any cleaning agents, to maintain the original glossy appearance from the factory.

3.4.4.2 Maintenance

Avoid prolonged static displays. Continuous display of unchanged images or pages may cause "image persistence" or "screen burn-in" on the screen.

If the monitor is not used for a long time (more than a week continuously), please unplug the power.

Excessive brightness and contrast settings can result in overly bright or dark screen display, affecting visual performance and potentially reducing the lifespan of the monitor. Adjust brightness and contrast reasonably according to ambient lighting and personal preferences.

Avoid placing the monitor in direct sunlight to prevent damage to the screen and reduce display effectiveness.

Extended usage is not beneficial for LCD monitors. When not in use, it is advisable to turn off the monitor's power.

Avoid collisions and vibrations when moving, handling, or cleaning the monitor to prevent damage to internal components.

Keep a distance from objects with strong magnetic fields as they can generate additional voltage within the monitor, affecting voltage stability. Prolonged exposure to strong magnetic fields can also cause color distortion, affecting LCD display performance and lifespan.

LCD monitors generate considerable heat, and prolonged usage can result in excessive internal temperatures, which can impact the lifespan of the LCD. Therefore, avoid placing LCD monitors in overheated areas.

Minimize the impact of static electricity on the monitor by using an anti-static wristband or touching a metal part to discharge static electricity.

Keep cables away from magnetic fields and avoid twisting or folding them to prevent monitor malfunctions.

Keep the power cord away from water sources, open flames, and high temperatures to prevent aging or damage that may cause safety hazards.

3.4.4.3 Repair

Please leave repair services to qualified, knowledgeable, and experienced repair engineers.

Do not attempt to repair or modify the equipment without prior authorization from the manufacturer.

Always use original components for replacements.

When reassembling, ensure that other intact components are placed back in their appropriate positions.

When disconnecting cables from electronic devices, take care not to damage the wire sections to avoid poor contact.

Use a screwdriver that matches the size of the screws when installing or removing screws.

TROUBLESHOOTING GUIDE

This section provides an overview of common types of product malfunctions and troubleshooting methods.

4 TROUBLESHOOTING GUIDE

4.1 Types of Malfunctions

For our touch display monitors, the common types of malfunctions can be categorized into touch-related issues and display-related issues.

4.2 Troubleshooting Process

If you encounter any abnormalities while using our touch display monitor, please first determine the type of malfunction, and then refer to the "Common Malfunction Reference Table" for preliminary analysis and assessment. If you are unable to troubleshoot the issue and restore normal operation, please follow our After-sales Process to request assistance.

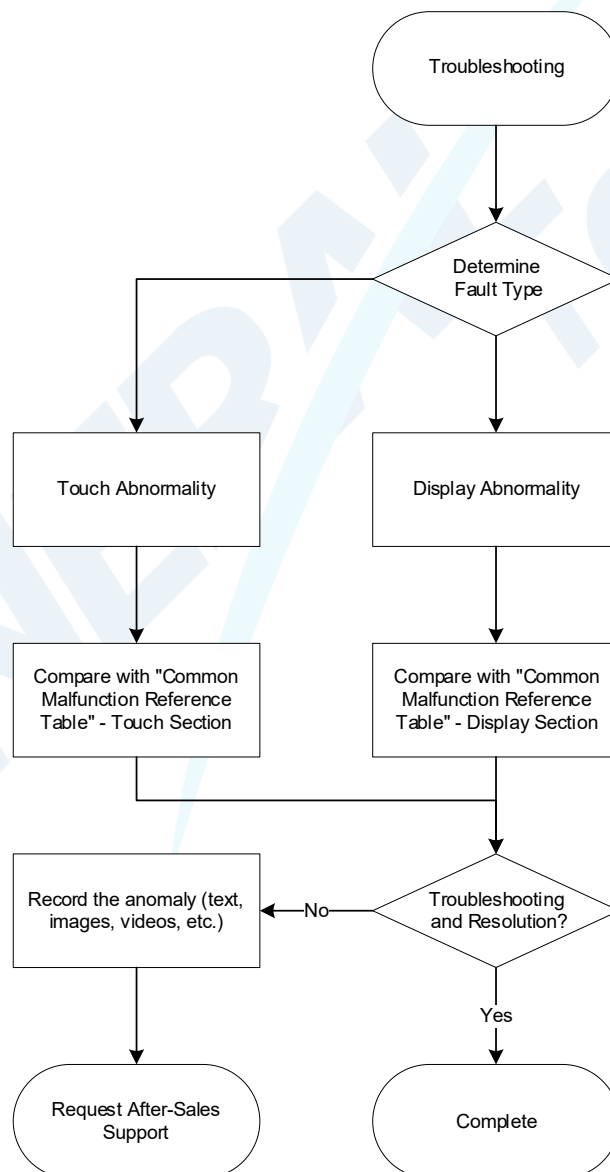

Fig 13 Common Troubleshooting Process

4.3 Common Malfunction Reference Table

If you encounter any malfunctions or abnormalities while using the touch display monitor, please refer to the following suggestions. If the issue persists, please contact your local dealer or reach out to General Touch’s after-sales support.

Table 2 Common Malfunction Reference Table

Fault Code	Fault Category	Common Issues	Possible Causes	Troubleshooting Methods	Fault Severity	
TP-1	Capacitive Touch	Erratic touch input	Program configuration error	Reconfigure parameters	I	
TP-2			External environmental interference	Measure static sensitivity through signal testing		
TP-3			Controller damage	Measure voltage or perform information testing		
TP-4		Broken lines at the edges or incomplete lines		Resolution mismatch	Specifically for some irregular screens, specialized resolutions need to be matched	II
TP-5				Resolution mismatch	Observe edge signal values through signal testing	
TP-6				Damaged edge channels	Visual observation or continuity testing Continuity testing	
				Damaged FPC ribbon cable or sensor	Continuity testing	
TP-7						
TP-8		Touch lock points		Abnormal screen panel	Perform signal testing and observe if the screen panel meets flatness standards	II
TP-9	Electromagnetic interference			Observe CDC static changes		

Fault Code	Fault Category	Common Issues	Possible Causes	Troubleshooting Methods	Fault Severity
TP-10			Controller malfunction	Perform cross-testing by replacing the screen panel	
TP-11				Test CDC static changes of the controller	
TP-12		Unresponsive touch (delayed or broken lines when drawing)	Decreased signal sensitivity	Read information values using information testing tools	II
TP-13			Outdated motherboard driver version	Reload driver software, mainly for Android or Linux	
TP-14			Abnormal firmware parameter	Reconfigure firmware parameters	
TP-15			Using fingertips instead of finger pad during touch testing	Perform touch testing using finger pad	
TP-16	Touch non-responsive		Touch display not connected to the host	Check if the host is connected or use the system "Device Manager" to see if devices are connected, and reconnect and reinsert signal cables	II
TP-17			Damaged signal cable	Replace signal cable (Type-B to Type-A)	
TP-18			Poor contact between touch screen and controller	Disassemble and reinsert FPC ribbon cables	
TP-19			Incorrect firmware or program writing	Reflash firmware	

Fault Code	Fault Category	Common Issues	Possible Causes	Troubleshooting Methods	Fault Severity
TP-10		Loose or disconnected screen wires	Other issues	Read screen panel signal waveform	II
TP-21			Abnormal sensor channels	Test channels through signal testing	
TP-22			Damaged sensor	Visual observation	
TP-23			Damaged FPC ribbon cable	Visual observation	
TP-24			Incorrect firmware parameter configuration	Update firmware	
D-1	Display	Black screen	Power not connected	Check if the power is properly connected and check the indicator light status (refer to section 3.2.2.2 for indicator light)	II
D-2			Video cable not connected	Connect and reconnect	
D-3			Other issues	Contact us	
D-4		Inverted display image	Incorrect OSD settings	Adjust in the OSD menu (refer to section 3.4.3.3.3 for "Picture" adjustment)	I
D-5		Screen distortion	Loose video cable	Connect and reconnect	II
D-6		Other issues	Any other display-related abnormalities	Contact us	II

SERVICE AND SUPPORT

This chapter mainly introduces our after-sales service and technical support.

GENERATOR TOUCH

5 SERVICE AND SUPPORT

5.1 Pre-sales Consultation

We provide professional pre-sales consultation services to our users. You can obtain timely and comprehensive information about our products and corresponding services through various channels such as our official website, email, and telephone.

5.2 After-sales Service

If you have any questions about the product or need assistance with equipment malfunctions, you can first refer to the user manual and frequently asked questions available on our website. If the issue persists, please contact us directly.

To provide global support, we collaborate with local representatives/service providers to assist customers with support and services. For more information, you can contact us or leave a message using the following methods, and we will respond promptly and provide assistance as soon as possible!

5.2.1 After-sales Process

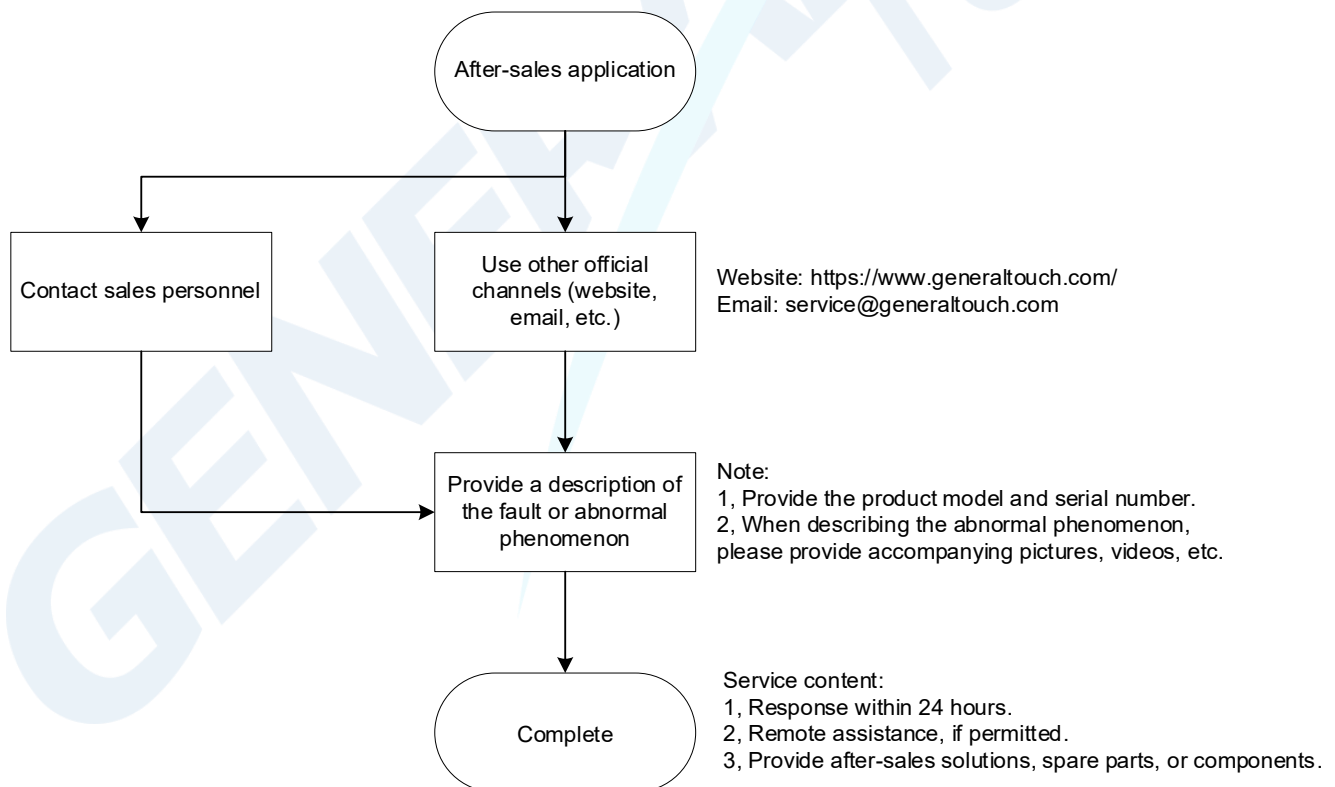

Fig 14 After-sales Process

5.2.2 Warranty Policy

The following is our product warranty commitment. During the warranty period, we provide free product repairs and replacement services for key components. For products that have exceeded the warranty period, we may charge a certain fee. For more details, please refer to our warranty policy on the official website under the "[Warranty Services](#)" section. Throughout the entire lifecycle of the product, you can expect comprehensive service from our company. The warranty policy provided below is for reference only. In case of any inconsistencies, the contract or specification sheet shall prevail.

Table 3 Warranty Policy

Touchscreen Components	SAW		5 Years
	PCAP		3 Years
	IR		1.5 Years
	FOG/Touch film/Touch Glass		6 months
	Resistive		1 Year
Touch Monitor	Flat	Not High TNI & High Brightness	3 Years
		High TNI & High Brightness	1 Year
	Curved		1 Year
Touch Computer (All-In-One)	With or without touch function		2 Years
Touch & Display Kits	Touchscreen and LCD panel bonded together		1 Year

5.2.3 Service Assurance

We are based in Chengdu, China, and have established after-sales repair centers in Europe. We also work with local agents and partners in the Americas, India, and other regions to provide diverse after-sales services.

We have dedicated departments and professionals to promptly and efficiently respond to customer needs. For common issues, we provide online consultation and support. For severe faults that require factory repairs, we offer return-to-factory repairs and the option of sending spare parts, based on our warranty policy.

5.3 Customization Services

We specialize in providing professional customized solutions for users. Based on your needs, we can offer complete product customization, such as touchscreens, touch displays, and all-in-one touch systems. You can learn about our customization service policies and options on the official website under "[Customer Customization](#)", or you can directly consult with us.

5.4 Debugging and Firmware Upgrades

Our panel mount touch displays usually do not require additional debugging and can be used directly. However, if you have specific requirements for touch experience, we also provide corresponding services, including touch calibration, touch signal testing, and firmware upgrades.

5.4.1 Debugging

5.4.1.1 Touch Calibration

Our touch displays are calibrated before leaving the factory and do not require manual calibration. However, for specific user requirements, we can provide calibration tools for you to choose from during the use of our products to adapt to different usage scenarios.

5.4.1.2 Touch Signal Testing

This is mainly provided when needed for maintenance or troubleshooting purposes, to assist you in identifying the source of faults.

5.4.2 Firmware Upgrades

For touch displays, our firmware includes touch-related firmware and display-related firmware. They are already adapted and debugged during the production process and do not require separate or additional firmware writing.

Our products support firmware upgrades for both functional improvements and fault troubleshooting. You can obtain firmware through official channels and use our dedicated tools. Please note that we reserve the right to refuse after-sales support for any damage or faults caused by the use of unofficial firmware provided by other companies.

5.4.2.1 Touch Firmware

Touch firmware upgrades can be directly written using software and can adjust touch sensitivity, sensing levels, etc.

5.4.2.2 Display Firmware

Display firmware needs to be written using separate tools and can preset features such as startup screen logo and display ratios.

APPENDIX

This chapter primarily introduces the product models within this series, as well as some terms and annotations.

GENERATOR TOUCH

6 APPENDIX

6.1 Specifications

6.1.1 Dimensions

For detailed dimensions and specifications, please refer to the sales drawings.

6.1.2 Technical Indicators

6.1.2.1 Display Parameters

For detailed specifications, please refer to the specification sheet.

6.1.2.2 Touch Performance

For conventional capacitive touch displays, they support up to 10-point touch with touch gestures including tapping and multi-point drawing. For acoustic touch displays, they support single-point touch with touch gestures including tapping and single-point drawing.

6.1.3 Environmental Adaptability

The general working environment for conventional models is as follows:

Operating temperature: 0 ~ 40°C.

Storage temperature: -20 ~ 60°C.

Operating humidity: 20% ~ 80%.

Storage humidity: 10% ~ 90%.

The above working environment requirements are based on common and general usage scenarios for conventional models.

6.2 Terms

OSD: On-Screen Display

PCAP: Projected Capacitive Touch

6.3 Contact Us

Address: No. 6, Keyuan South Road, Chengdu High-tech Zone, Sichuan Province, China

This manual may be subject to updates without prior notice.

You can check the latest version on the General Touch official website or contact us directly.

<https://www.generaltouch.com/>

If you have any questions or suggestions regarding the user manual, please contact us via the following email: info@generaltouch.com.

General Touch is a registered trademark of General Touch Co., Ltd.

Copyright © 2026 General Touch. All rights reserved.